



RED SWASTIKA SCHOOL

# RED SWASTIKA SCHOOL

## 2008 CONTINUAL ASSESSMENT 1

### MATHEMATICS

Name : \_\_\_\_\_ (      )

Class : Primary 6 / \_\_\_\_\_

Date : 26 February 2008

### BOOKLET A

15 Questions

20 Marks

Duration of Paper : 2 hours 15 minutes

Note:

1. Do not open this Booklet until you are told to do so.
2. Questions 1 - 15 are to be done on the OAS provided.
3. Read carefully the instructions given at the beginning of each part of the Booklet.
4. Do not waste time. If a question is difficult for you, go on to the next one.
5. Check your answers thoroughly and make sure you attempt every question.

Questions 1 to 10 carry 1 mark each. Questions 11 to 15 carry 2 marks each. For each question, four options are given. One of them is the correct answer. Make your choice (1, 2, 3 or 4). Shade the correct oval (1, 2, 3 or 4) on the Optical Answer Sheet. (20 marks)

---

1 Simplify  $3 + 8x - 2 - 5x$ .

- (1)  $1 + 3x$
- (2)  $5 + 3x$
- (3)  $1 + 13x$
- (4)  $5 + 13x$

2 The figure below shows a net of a solid.

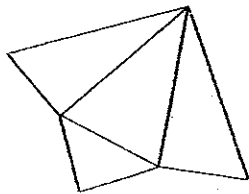

Which one of the following solids can be obtained by folding the net above?

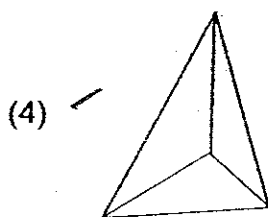
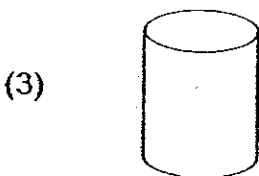
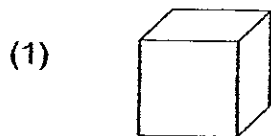

- 3 In the figure not drawn to scale, PQ, RS and TU are straight lines. Find  $\angle m$ .

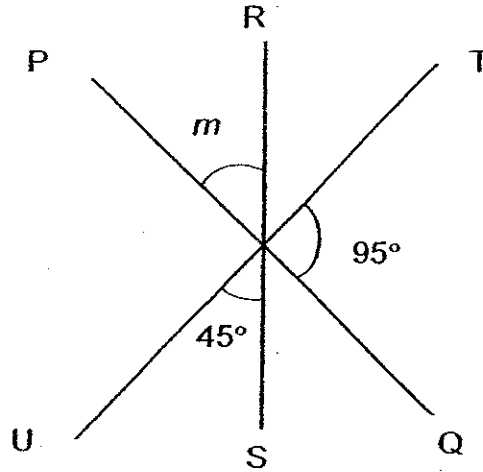

- (1)  $40^\circ$
- (2)  $85^\circ$
- (3)  $140^\circ$
- (4)  $220^\circ$

- 4 The figure below is not drawn to scale. PQRS is a rhombus.  $\angle QRS = 110^\circ$  and  $\angle PSQ = 35^\circ$ . Find  $\angle QSR$ .

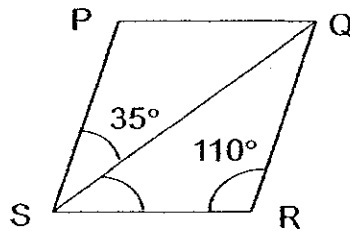

- (1)  $35^\circ$
- (2)  $55^\circ$
- (3)  $70^\circ$
- (4)  $75^\circ$

- 5 The figure below is not drawn to scale. PQRS is a parallelogram and  $\angle SPQ = 118^\circ$ . What is the value of  $\angle x + \angle y$ ?

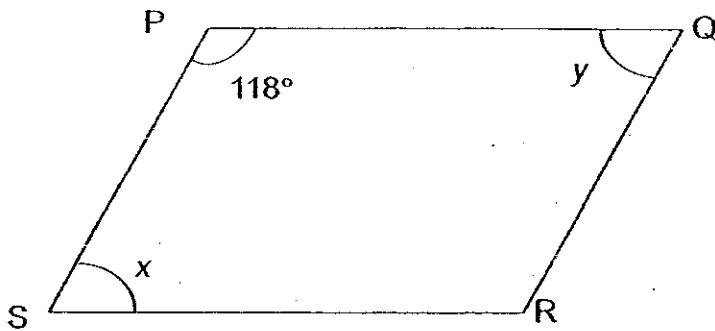

- (1)  $118^\circ$   
 (2)  $124^\circ$   
 (3)  $236^\circ$   
 (4)  $298^\circ$
- 6 The rectangle below is divided into 3 parts. The ratio of Area P to Area Q is 3 : 5. The ratio of Area Q to Area R is 10 : 16. Find the ratio of Area P to Area Q to Area R.

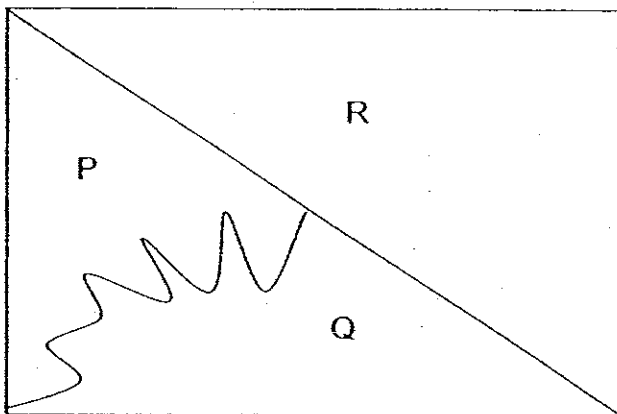

- (1) 3 : 5 : 16  
 (2) 3 : 10 : 16  
 (3) 3 : 15 : 16  
 (4) 6 : 10 : 16

7 Josephine and Daisy had some stickers in the ratio 2 : 5. If Josephine had 36 stickers fewer than Daisy, how many stickers did both of them have altogether?

- (1) 12
- (2) 24
- (3) 60
- (4) 84

8 The mass of Jane is  $3\frac{1}{2}$  times the mass of Peter.  
Find the ratio of the mass of Jane to the mass of Peter.

- (1) 1 : 3
- (2) 1 : 7
- (3) 2 : 7
- (4) 7 : 2

9 The figure below is not drawn to scale. PQRS is a parallelogram and FQS is a straight line.  $\angle QRS = 60^\circ$  and  $\angle FQR = 95^\circ$ . Find  $\angle PQF$ .

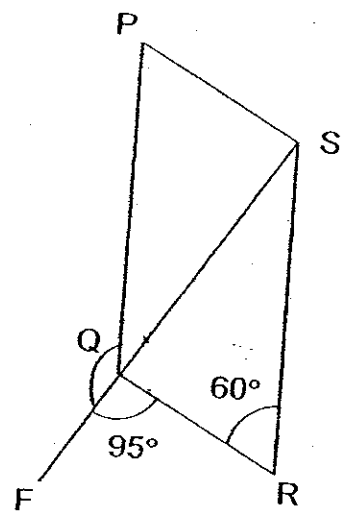

- (1) 85°
- (2) 120°
- (3) 145°
- (4) 155°

- 10 At a party, the ratio of the number of children to the number of adults was  $36 : 5$ . The ratio of the number of men to the number of women was  $1 : 2$ . What was the ratio of the number of children to the number of men?

- (1)  $108 : 2$
- (2)  $108 : 5$
- (3)  $108 : 15$
- (4)  $5 : 108$

- 11 The figure below is not drawn to scale.  $ABC$  is an isosceles triangle where  $AB = AC$ .  $GCA$  is a straight line. Find  $\angle x$ .

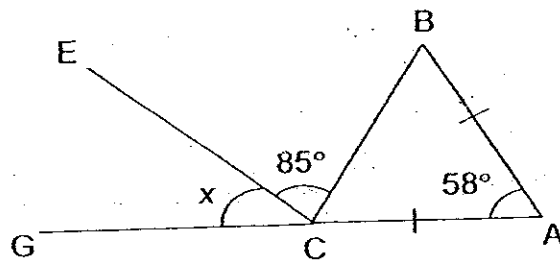

- 12 Lynn bought 5 cups and 6 plates for  $\$y$ . If 1 cup cost 80 cents, find the cost of 1 plate in terms of  $y$ .

- (1)  $\$ \left( \frac{y - 80}{5} \right)$
- (2)  $\$ \left( \frac{y - 4}{6} \right)$
- (3)  $\$ (5y - 4)$
- (4)  $\$ (6y - 4)$

13 Janet and Mariam had two dozens stalks of roses each. Janet sold  $\frac{1}{4}$  of her roses while Mariam sold  $\frac{2}{3}$  of hers. What was the ratio of the total number of stalks of roses left to the total number of stalks of roses sold?

- (1) 3 : 8
- (2) 8 : 3
- (3) 11 : 13
- (4) 13 : 11

14 The figure below shows a rectangular block of wood. What is the maximum number of 5-cm cubes that can be cut from the block?

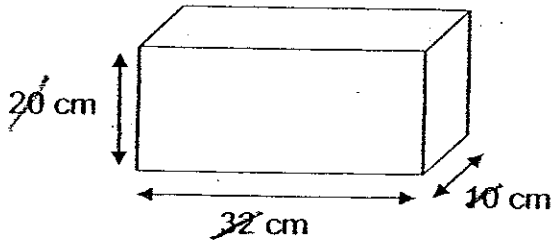

- (1) 48
- (2) 52
- (3) 56
- (4) 1280

15 Xiao Min gave  $\frac{1}{4}$  of his pocket money to charity and spent  $\frac{1}{2}$  of the remainder on food. If he spent \$24 on food, how much was his pocket money?

- (1) \$32
- (2) \$56
- (3) \$64
- (4) \$100



RED SWASTIKA SCHOOL

# RED SWASTIKA SCHOOL

## 2008 CONTINUAL ASSESSMENT 1

### MATHEMATICS

Name : \_\_\_\_\_ ( )

Class : Primary 6 / \_\_\_\_\_

Date : 26 February 2008

### BOOKLET B

33 Questions

80 Marks

#### MARKS

	OBTAINED	POSSIBLE
BOOKLET A		20
BOOKLET B		80
TOTAL		100

Parent's Signature : \_\_\_\_\_

Questions 16 to 25 carry 1 mark each. Write your answers in the spaces provided. For questions which require units, give your answers in the units stated. (10 marks)

16 The table below shows the postage rates for sending letters, magazines and parcels to Malaysia.

Mass step not over	Postage
20 g	\$0.45
50 g	\$0.55
100 g	\$0.85
Per additional step of 100 g	\$1.00

Matthew sent a parcel of 573 g to his penpal in Malaysia. Find the postage he paid for the parcel.

Ans: \$ \_\_\_\_\_

17 Timothy bought some mangoes at \$6 each. He gave the fruit seller \$130 and received \$y as change. How many mangoes did he buy?

Ans: \_\_\_\_\_

18 If 7 identical pens cost \$24.50, find the cost of 9 such pens.

Ans: \$ \_\_\_\_\_

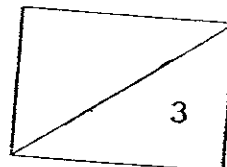

- 19 The height of a tank is 25 cm and the breadth is 20 cm. The capacity of the tank is 7.5 l. What is the length of the tank?

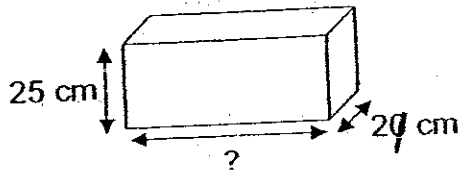

Ans: \_\_\_\_\_ cm

- 20 The figure below is not drawn to scale. ABCD is a parallelogram and XCB is an isosceles triangle.  $XC = BC$  and XD is a straight line. Find  $\angle CXD$ .

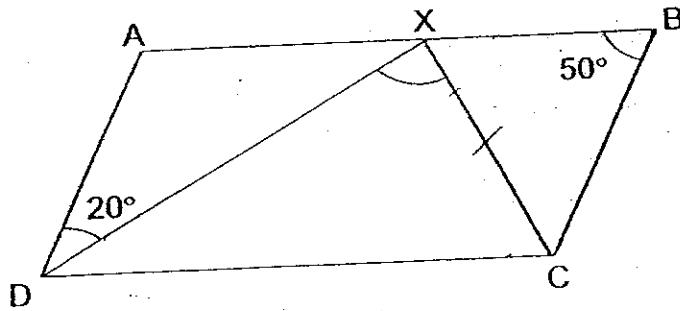

Ans: \_\_\_\_\_ °

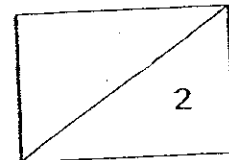

- 21 The figure below is not drawn to scale. ABC and DBE are straight lines. If  $EB = EC$  and  $\angle ABD = 46^\circ$ , find  $\angle x$ .

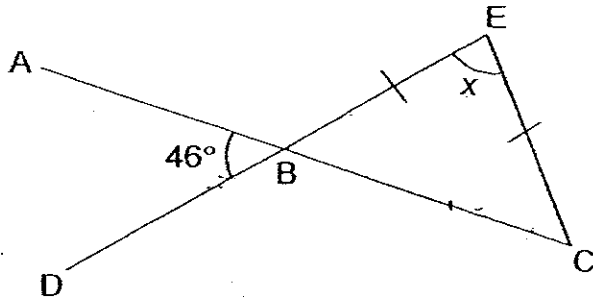

Ans: \_\_\_\_\_<sup>o</sup>

- 22 The average number of sweets Jane, Ashley and Lydia have is 125. The total number of sweets Jane and Ashley has is 230. How many sweets does Lydia have?

Ans: \_\_\_\_\_

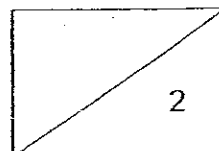

''

- 23 Oranges are sold in bags of 7. Each bag of oranges costs \$4. Jack has \$22. What is the maximum number of oranges he can buy?

Ans: \_\_\_\_\_

---

- 24 The ratio of the cost of a jersey to the cost of a pair of shoes is 5 : 8. The jersey costs \$36 less than the pair of shoes. What is the total cost of the jersey and the pair of shoes?

Ans: \$ \_\_\_\_\_

---

- 25 Find the value of  $2x - \frac{x}{3}$  when  $x = 6$ .

Ans: \_\_\_\_\_

---

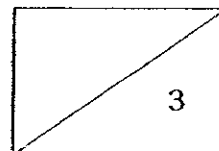

Questions 26 to 35 carry 2 marks each. Show your working clearly in the space below each question and write your answers in the spaces provided. For questions which require units, give your answers in the units stated. (20 marks)

26 Ali had  $19m$  candies. He gave  $3m$  candies to his teacher, 4 candies to his neighbour and gave the remainder equally to his 5 classmates. Express the number of candies each classmate received in terms of  $m$ .

Ans: \_\_\_\_\_

27 In a tray, there are cupcakes, cookies and doughnuts. The ratio of the number of cupcakes to the number of cookies is 3 : 2. The ratio of the number of cookies to the number of doughnuts is 1 : 5. What is the ratio of the number of doughnuts to the total number of pastries on the tray? (Give your answer in its simplest form.)

Ans: \_\_\_\_\_

28 Rui Xuan is  $p$  years old and his father is 3 times as old as he. What is the total age of Rui Xuan and his father in 5 years' time in terms of  $p$ ?

Ans: \_\_\_\_\_ years

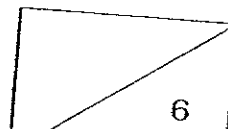

- 29 The figure below is not drawn to scale. PQRS is a trapezium. TQR and PQU are straight lines.  $\angle QRS = 62^\circ$ . Find  $\angle x$ .

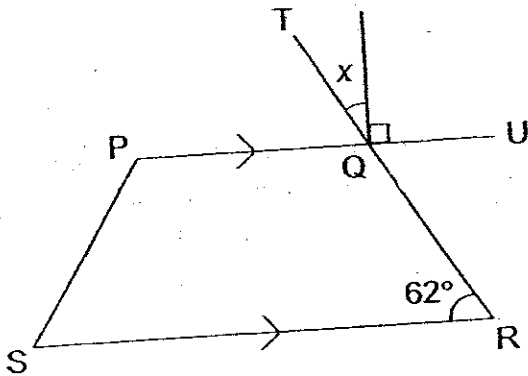

Ans: \_\_\_\_\_

- 30 Andreas and Tristan shared a box of marbles in the ratio 5 : 1. After Andreas gave Tristan 30 of his marbles, they had the same number of marbles. What was the total number of marbles they had at first?

Ans: \_\_\_\_\_

- 31 The perimeter of a triangle is 48 cm. The sides of the triangle are in the ratio of 5 : 3 : 4. Find the difference between the length of the longest side and the length of the shortest side of the triangle.

Ans: \_\_\_\_\_ cm

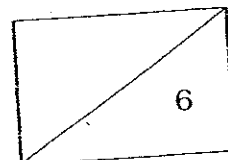

- 32 In the figure below, three identical squares  $X$  and two circles  $P$  lie within a large square  $ABCD$ . The area of a square  $X$  is equal to the area of a circle  $P$ . What is the ratio of the area of the shaded part to the total area of the square  $ABCD$ ?

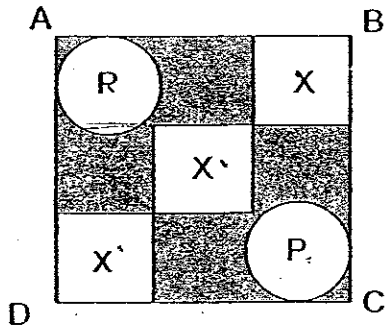

Ans: \_\_\_\_\_

- 33 In the figure below, which is not drawn to scale,  $\angle JLM = 90^\circ$ ,  $\angle JKN = 115^\circ$  and  $\angle LMN = 55^\circ$ .  $NK = NL$ . Find  $\angle LNM$ .

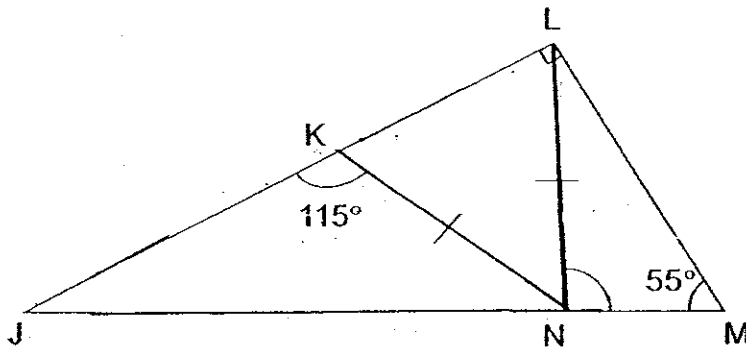

Ans: \_\_\_\_\_<sup>o</sup>

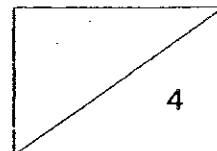

- 34 In the figure below, which is not drawn to scale, TUVW is a parallelogram.  $TU = TS$ ,  $\angle RUV = 100^\circ$  and  $\angle WVU = 55^\circ$ . Find  $\angle WTS$ .

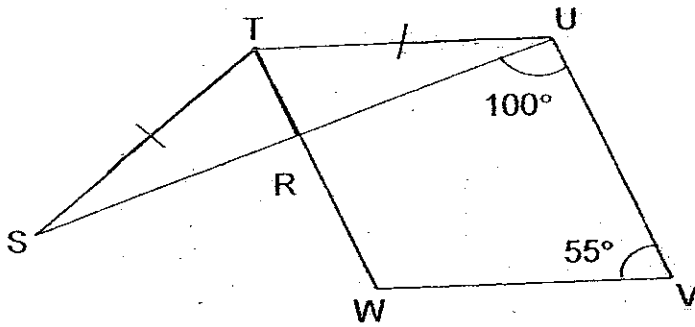

Ans: \_\_\_\_\_°

- 35 The figure below is not drawn to scale. ABDE is a parallelogram and ABC is an isosceles triangle where  $BA = BC$ .  $\angle AED = 40^\circ$  and  $\angle DCB = 38^\circ$ . Find  $\angle DBC$ .

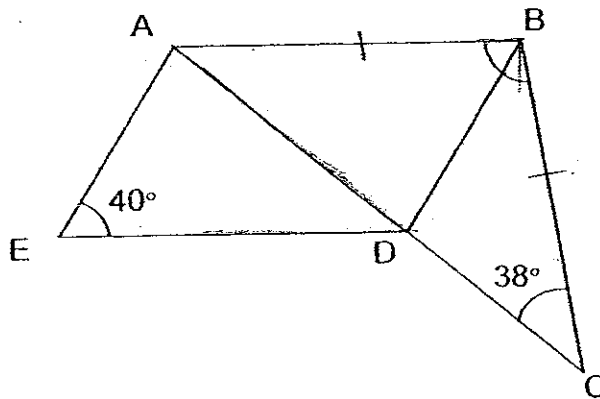

Ans: \_\_\_\_\_°

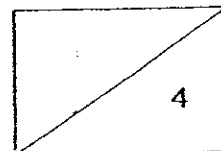

For Questions 36 to 48, show your working clearly in the space below each question and write your answers in the spaces provided.  
 The number of marks available is shown in brackets [ ] at the end of each question or part-question. (50 marks)

36 The figure below shows a cuboid measuring 10 cm by 5 cm by 3y cm.

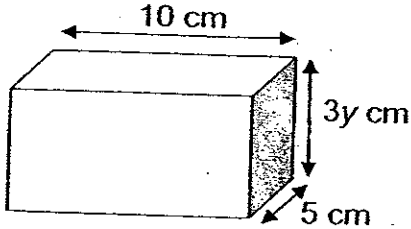

- (a) Find the perimeter of the shaded face of the cuboid in terms of  $y$ .  
 (b) If  $y = 6$ , what is the perimeter of the shaded face?

Ans: (a) \_\_\_\_\_ [2]

(b) \_\_\_\_\_ [1]

37 In the figure below, not drawn to scale, OPQ is an isosceles triangle in which  $OP = OQ$  and  $\angle OQP = 61^\circ$ . Find  $\angle a$ .

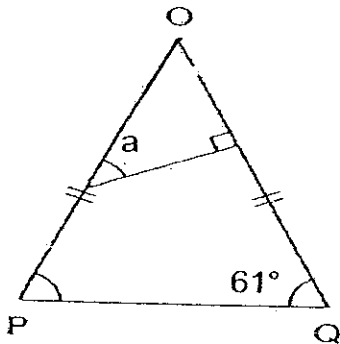

Ans: \_\_\_\_\_ [3]

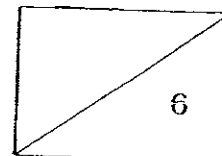

17

38 In the figure below, not drawn to scale, DEF is a straight line and line HE is perpendicular to line DEF.  $\angle GEF=60^\circ$ ,  $\angle EFG=35^\circ$  and  $GH = GE$ .

(a) Find  $\angle p$ .

(b) Find  $\angle q$ .

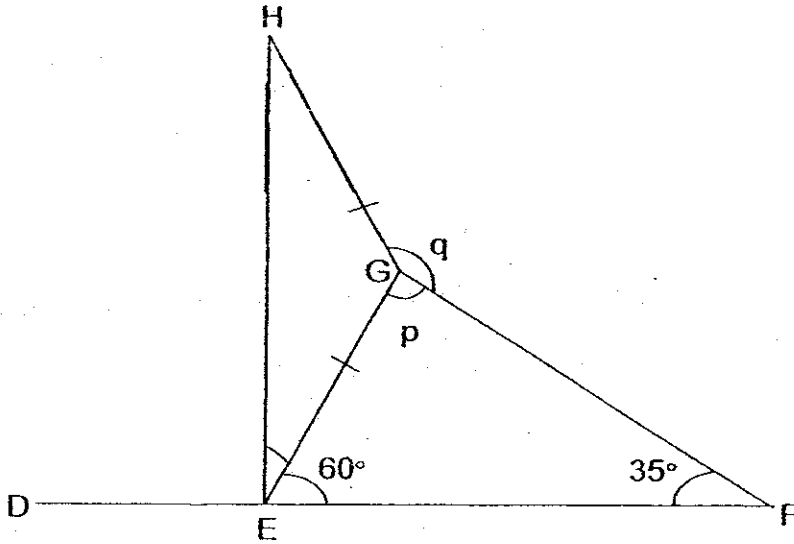

Ans: (a) \_\_\_\_\_ [1]

(b) \_\_\_\_\_ [2]

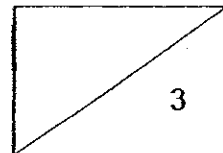

- 39 Tom, Jerry and Daniel had some stickers. The total number of stickers Jerry and Daniel had was two times as many as Tom. The ratio of the number of stickers Jerry had to the number of stickers Daniel had was 3 : 5. Tom and Daniel had 180 stickers altogether. How many stickers did Tom have?

Ans: \_\_\_\_\_ [3]

- 40 In the figure, not drawn to scale, PR is perpendicular to RT. AQ, BR and CS are parallel lines. Find  $\angle y$ .

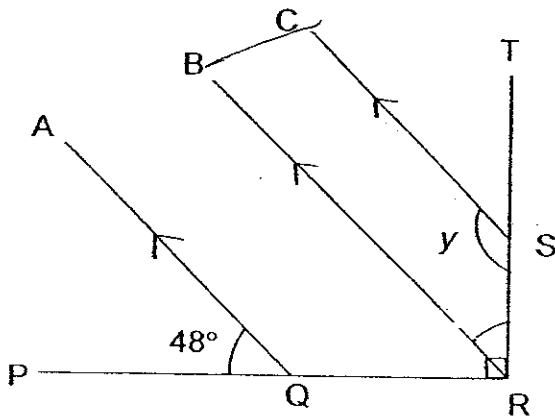

Ans: \_\_\_\_\_ [3]

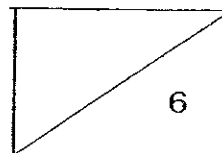

- 41 Auntie May cooked 520 fishballs and sotong balls altogether. She sold 75% of the fishballs and 50% of the sotong balls. She was left with 180 fishballs and sotong balls altogether. How many fishballs did she cook at first?

Ans: \_\_\_\_\_ [3]

---

- 42 An eraser costs  $x$  cents and a pen costs 80 cents more than an eraser.
- (a) What is the cost of 3 erasers and 1 pen in terms of  $x$ ?
- (b) Jerome wants to buy 3 erasers and 1 pen but is short of 20 cents. If the eraser costs 70 cents, how much money does Jerome have?

Ans: (a) \_\_\_\_\_ [2]

(b) \_\_\_\_\_ [2]

---

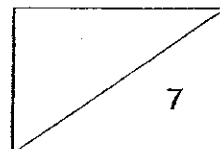

43 The rates of charges for taxi fare are as follows.

Distance Travelled	Cost
1 km or less	\$2.80
Every 200 metres thereafter or less up to 10 km	\$0.20
Every 30 seconds of waiting or less	\$0.10

Jack took a taxi from his house to Tampines. The total distance travelled was 6 km 600 m. During the journey, the taxi stopped at traffic junctions. It stopped for 120 seconds at the junctions. Find the taxi fare Jack had to pay.

Ans: \_\_\_\_\_ [4]

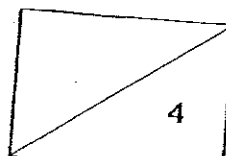

- 44 Four rectangles Y, as shown in Figure 1, are used to surround the rectangle Z to form another rectangle ABCD as shown in Figure 2. The perimeter of rectangle ABCD is 28 cm and the area of rectangle Z is  $24 \text{ cm}^2$ . What is the length of rectangle Z?

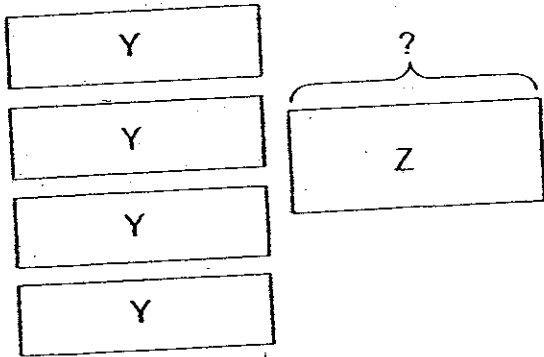

Figure 1

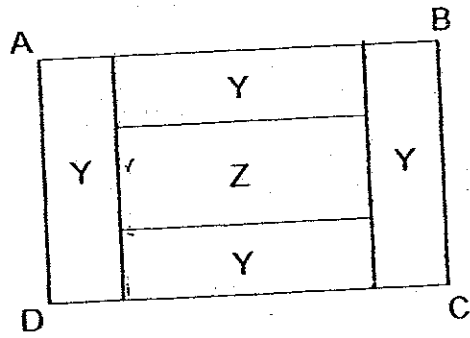
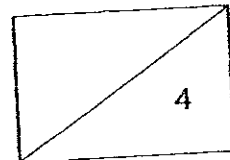

Figure 2

Ans: \_\_\_\_\_ [4]



45 A carton of cherries was shared between Joe and Fatimah in the ratio 2 : 5. Joe gave  $\frac{1}{2}$  of <sup>his</sup> cherries to Fatimah. After receiving the cherries from Joe, Fatimah then gave  $\frac{1}{4}$  of what she had to Joe. In the end, Fatimah had 20 more cherries than Joe.

- (a) How many cherries did Joe have in the end?  
 (b) How many cherries did Fatimah have at first?

Ans: (a) \_\_\_\_\_ ~~21~~ 3  
 (b) \_\_\_\_\_ ~~21~~ 2

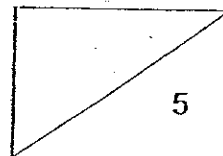

23

46 In a pet shop,  $\frac{3}{10}$  of the animals are hamsters. The rest of the animals are birds and fishes. The ratio of the number of birds to the number of fishes is 9 : 5. There are 360 more birds than fishes.

- (a) How many animals are there altogether?
- (b) How many more hamsters than fishes are there?

Ans: (a) \_\_\_\_\_ [2]

(b) \_\_\_\_\_ [3]

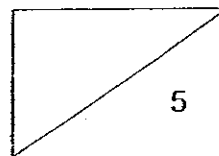

- 47 The ratio of the number of marbles Jimmy has to the number of marbles Tim has was 3 : 4 at first. After Jimmy gave Tim 36 marbles, the ratio of Jimmy's marbles to Tim's marbles became 1 : 2. What was the total number of marbles they had altogether?

Ans: \_\_\_\_\_ [5]

---

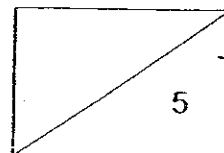

25

48 In the figure, not drawn to scale, ABC is an isosceles triangle where  $AC = CB$ . BCDE is a rhombus. ACE is a straight line and  $\angle ACB = 130^\circ$ .

(a) Find  $\angle BCE$ .

(b) Find  $\angle ABE$ .

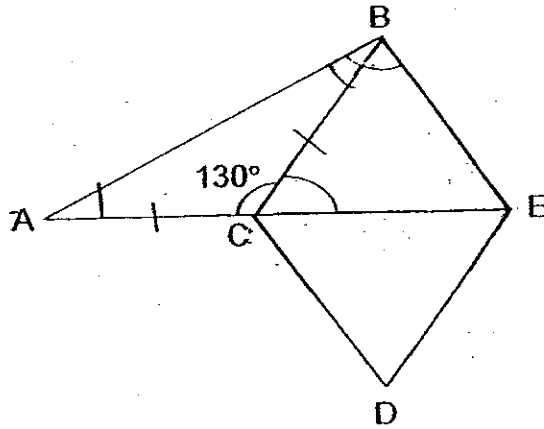

Ans: (a) \_\_\_\_\_ [1]

(b) \_\_\_\_\_ [4]

END OF PAPER

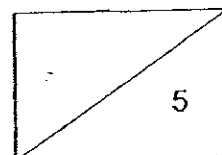

EXAM PAPER 2008

SCHOOL : RED SWASTIKA PRIMARY SCHOOL  
SUBJECT : PRIMARY 6 MATHEMATICS

TERM : CA 1

Q1	Q2	Q3	Q4	Q5	Q6	Q7	Q8	Q9	Q10	Q11	Q12	Q13	Q14	Q15
1	4	1	1	2	4	4	4	3	2	1	2	4	1	3

16) \$5.85      17) \$(130-y)      18) \$31.50      19) 15      20) 100

21) 88°      22) 145      23) 35      24) \$156      25) 10

26) (16m-4)      27) 2-3      28) 4p+10      29) 28°      30) 90

31) 8      32) 4/9      33) 100      34) 75      35) 64°

36) a) Perimeter =  $3y + 3y + 5 + 5$   
 $= (6y + 10) \text{ cm}$   
 b) Perimeter =  $6 \times 6 + 10$   
 $= 46 \text{ cm}$

37)  $\angle POQ = 180^\circ - 61^\circ - 61^\circ = 58^\circ$   
 $\angle a = 180^\circ - 58^\circ - 90^\circ = 32^\circ$

38) a)  $\angle p = 180^\circ - 60^\circ - 35^\circ = 85^\circ$   
 b)  $\angle HEG = 90^\circ - 60^\circ = 30^\circ$   
 $\angle HEG = 180^\circ - 30^\circ - 30^\circ = 120^\circ$   
 $\angle q = 360^\circ - 85^\circ - 120^\circ = 155^\circ$

39) T : J : D

4 : 3 : 5

$$3+5=8$$

$$8 \div 2 = 4$$

$$4+5=9u$$

$$9u \rightarrow 180$$

$$4u \rightarrow 180 \times \frac{4}{9}$$

$$= 80$$

= 80 stickers.

$$40) 90^\circ - 48^\circ = 42^\circ$$

$$Y = 180^\circ - 42^\circ = 138^\circ$$

41)

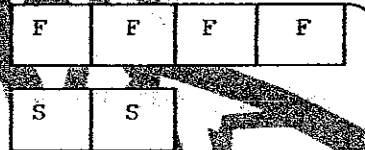

520

$$1F + 1S = 180$$

$$2F + 2S = 180 \times 2 = 360$$

$$2F = 520 - 360 = 160$$

$$1F = 160 \div 2 = 80$$

$$4F = 80 \times 4 = 320 \text{ fishballs.}$$

$$42) a) 1 \text{ pen} = (x+80)\text{¢}$$

$$3 \text{ Eraser} + 1 \text{ pen}$$

$$= 3x + x + 80$$

$$= (4x + 80)\text{¢}$$

$$b) 4 \text{¢} + 80 = 4 \times 70 + 80$$

$$= 20 + 80 = 360\text{¢}$$

$$360\text{¢} - 20 = 340\text{¢}$$

$$= \$3.40$$

43)  $6\text{km } 600\text{m} - 1\text{km} = 5\text{km } 600\text{m}$

$\frac{5600}{200} = 28$

$\frac{200}{28} = 7$

$28 \times \$0.20 = \$5.60$

$\frac{120}{30} = 4$

$\frac{30}{4} = 7.5$

$4 \times \$0.10 = \$0.40$

$\$2.80 + \$5.60 + \$0.40 = \$8.80$

44)  $A \quad b \quad L \quad b \quad B$

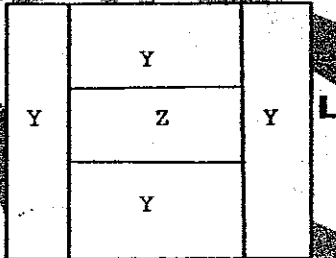

$4L + 4b = 28$

$1L + 1b = \frac{28}{4} = 7$

Length of rectangle Z = length of rectangle Y  
It must be less than 7cm

Area of Z =  $24\text{cm}^2 = 4\text{cm} \times 6\text{cm}$

Length of rectangle Z = 6cm

45) a) J : F

$2 : 5$

$\frac{-1}{1} : \frac{+1}{1}$

$1 : 6$

$+\frac{1}{2} : -\frac{1}{2}$

$2\frac{1}{2} : 4\frac{1}{2}$

$4\frac{1}{2} - 2\frac{1}{2} = 2u$

$2u = 20$

$1u = 10$

$2\frac{1}{2} = 2\frac{1}{2} \times 10 = 25 \text{ cherries.}$

b)  $5u = 10 \times 5 = 50 \text{ cherries.}$

$$46) a) 6+9+5=20u$$

$$9-5=4u$$

$$4u=360$$

$$1u = \frac{360}{4} = 90$$

$$20u = 90 \times 20 = 1800 \text{ animals.}$$

$$b) 6-5=1u$$

$$1u = 90 \text{ more hamsters than fishes.}$$

$$47) J : T$$

$$3 : 4 = 7$$

$$\begin{array}{r} \times 3 \\ \hline 9 : 12 = 21 \end{array}$$

$$J : T$$

$$1 : 2 = 3$$

$$\begin{array}{r} \times 7 \\ \hline 7 : 14 = 21 \end{array}$$

$$9-7=2u$$

$$2u=36$$

$$1u = \frac{36}{2} = 18$$

$$21u = 21 \times 18 = 378 \text{ marbles.}$$

$$48) a) \angle BCE = 180^\circ - 130^\circ = 50^\circ$$

$$b) \angle ABC = 180 - 130 = 25^\circ$$

2

$$\angle CBE = 180 - 50 - 50 = 80^\circ$$

$$\angle ABE = 25^\circ + 80^\circ = 105^\circ$$

---end---