



RAFFLES GIRLS' PRIMARY SCHOOL

SEMESTRAL ASSESSMENT 1 2009 Paper 1

Name : _____ () Class: P5 ___
Banded Class: P5 ___

12 May 2009 MATHEMATICS Att: 50 min

Your Score Out of 40 marks		
	Banded Class	Level
Highest score		
Average score		
Parent's Signature		

You are not allowed to use a calculator for this paper.

SECTION A (20 marks)

Questions 1 to 10 carry 1 mark each. Question 11 to 15 carry 2 marks each. For each question, four options are given. One of them is the correct answer. Make your choice (1, 2, 3 or 4). Shade your answer (1, 2, 3 or 4) on the OAS provided. All diagrams are not drawn to scale.

1. About 16 000 visitors went to an exhibition when rounded off to the nearest thousand. Which could be the possible number of visitors?

- (1) 15 099
- (2) 15 533
- (3) 16 505
- (4) 16 909

()

2. What is the best estimate for 3948×29 ?

- (1) 3000×20
- (2) 3000×30
- (3) 4000×20
- (4) 4000×30

()

3. Find the volume of the cuboid shown below.

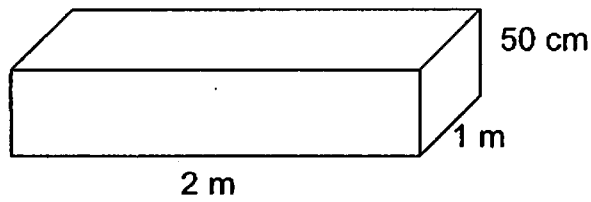

- (1) 0.1 m^3
- (2) 1 m^3
- (3) 10 m^3
- (4) 100 m^3

()

4. Express $\frac{28}{12}$ as a mixed number in its simplest form.

- (1) $2\frac{1}{3}$
- (2) $2\frac{2}{3}$
- (3) $2\frac{2}{6}$
- (4) $2\frac{1}{4}$

()

5. What fraction of the figure below is shaded? Give your answer in its simplest form.

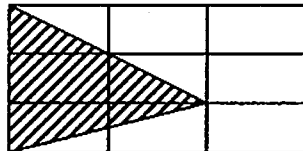

- (1) $\frac{1}{6}$
- (2) $\frac{1}{3}$
- (3) $\frac{4}{9}$
- (4) $\frac{5}{9}$

() ✓

6. Which of the following is not a tessellation?

(1)

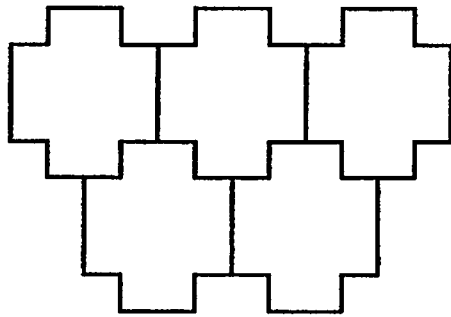

(2)

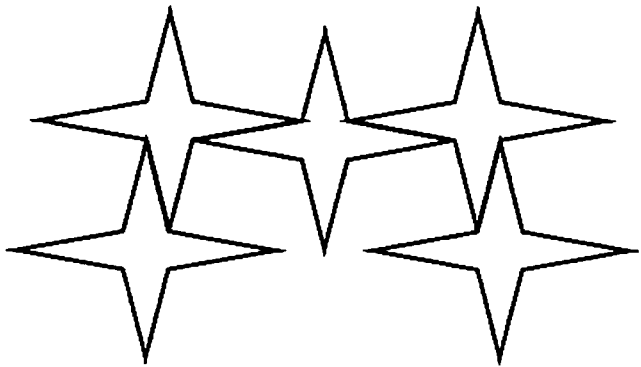

(3)

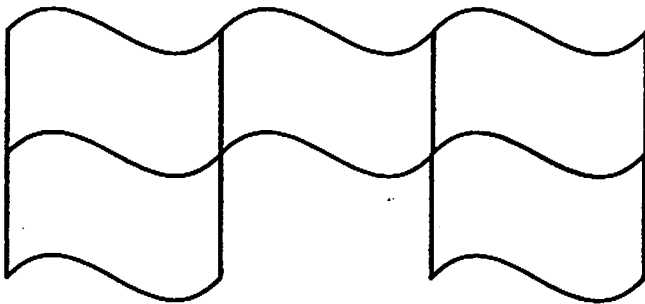

(4)

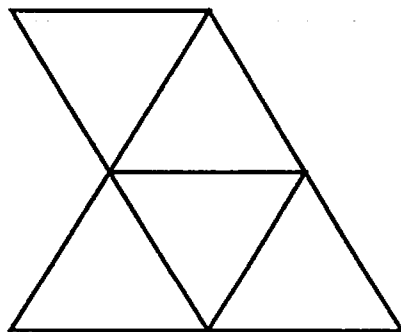

()

7. In 452.369, what is the place value of the digit 6?

- (1) Hundredths
- (2) Tenths
- (3) Tens
- (4) Hundreds

()

8. $4.25 + 42.5 =$ _____

- (1) 4.675
- (2) 8.50
- (3) 46.75
- (4) 85.0

()

9. Which of the following ratio is the same as 6 : 9 ?

- (1) 3 : 2
- (2) 8 : 11
- (3) 10 : 15
- (4) 12 : 27

()

10. When the digit '7' in the number 472 589 is replaced by the digit '3', what is the difference between the two numbers?

- (1) 400
- (2) 4 000
- (3) 40 000
- (4) 400 000

()

11. Multiply the sum of all the factors of 4 with the fourth multiple of 7.

- (1) 7
- (2) 11
- (3) 28
- (4) 196

()

12. Each of the squares below is made up of 8 triangles. Which of the square has a line of symmetry?

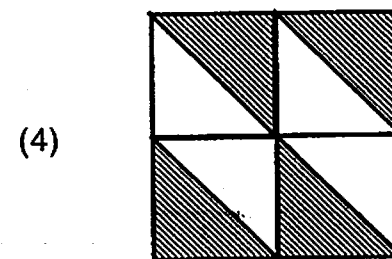
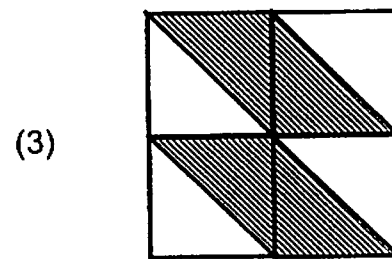
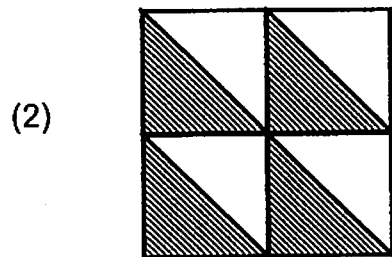
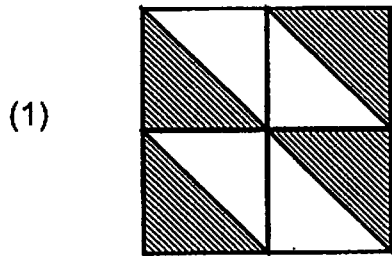

()

13. Karen had 128 beads. She gave $\frac{1}{4}$ of them to Liping and $\frac{3}{8}$ of the remainder to Siti. How many beads did Siti get?

- (1) 32
 (2) 36
 (3) 60
 (4) 96

()

14. The solids shown below are made up of 1-cm cubes.

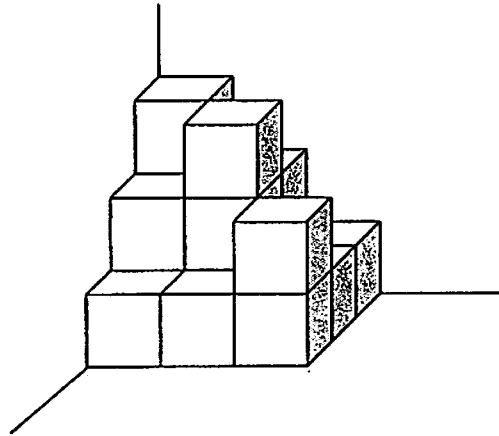

Which of the following solid has the same number of cubes as the above?

(1)

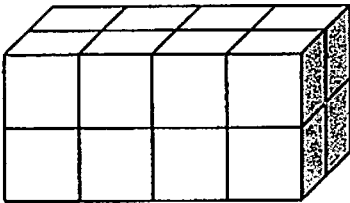

(2)

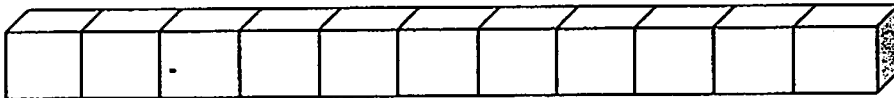

(3)

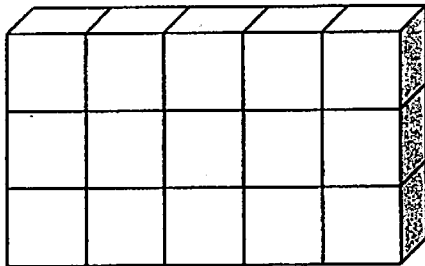

(4)

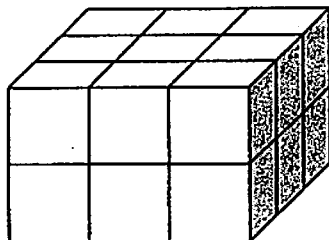

()

15. Triangle ABC and Triangle CBD are drawn on two different sets of 1-cm grids.

Which of the following is the best estimation of their total area?

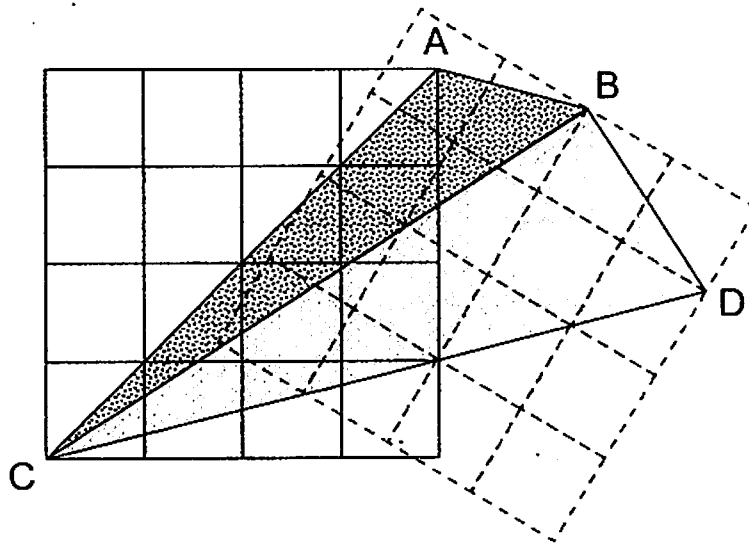

- (1) 7 cm^2
- (2) 9 cm^2
- (3) 11 cm^2
- (4) 13 cm^2

()

SECTION B (20 marks)

Questions 16 to 25 carry 1 mark each. Write your answers in the spaces provided. For questions which require units, give your answers in the units stated. All diagrams are not drawn to scale. Answers in fractions or ratio must be expressed in the simplest form.

16. Write 2 012 548 in words.

17. Arrange the following in descending order:

0.245, $\frac{9}{20}$, 0.352, $\frac{1}{4}$

Ans: _____

18. Lina mixed a bottle of guava juice, a can of apple soda and a packet of lime juice to create her favourite mocktail for her family. What is the volume of the mocktail in litres?



**Guava
Juice**
2 l



**Apple
Soda**
330 ml

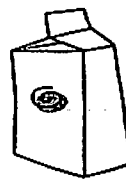

**Lime,
Juice**
750 cm³

Ans: _____ l

19. Complete the figure below so that line AB is the line of symmetry.

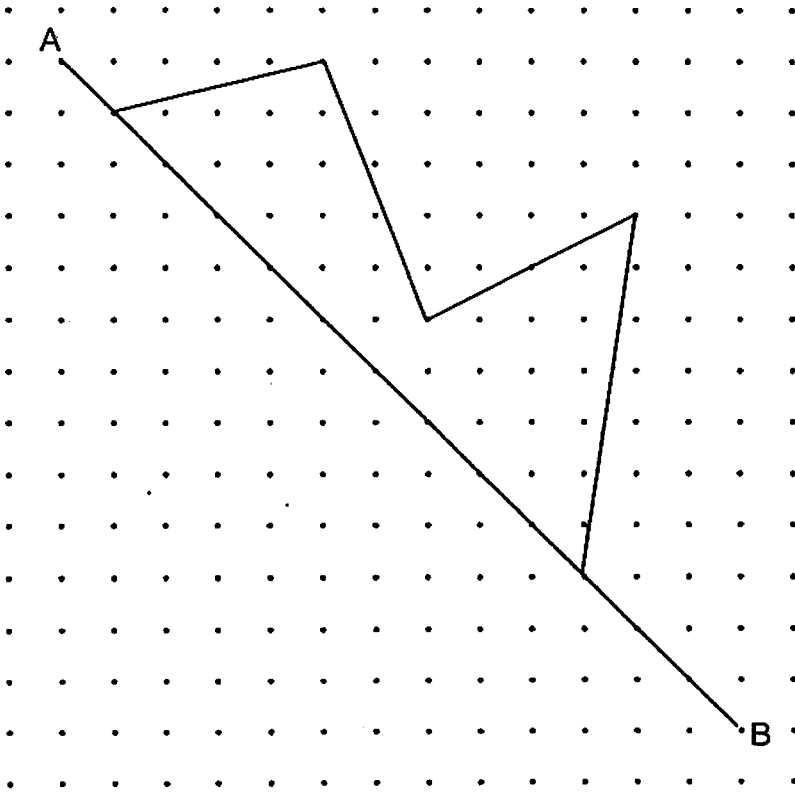

20. The pattern in the box shows part of a tessellation. Extend the tessellation by drawing two more unit shapes in the space provided in the box.

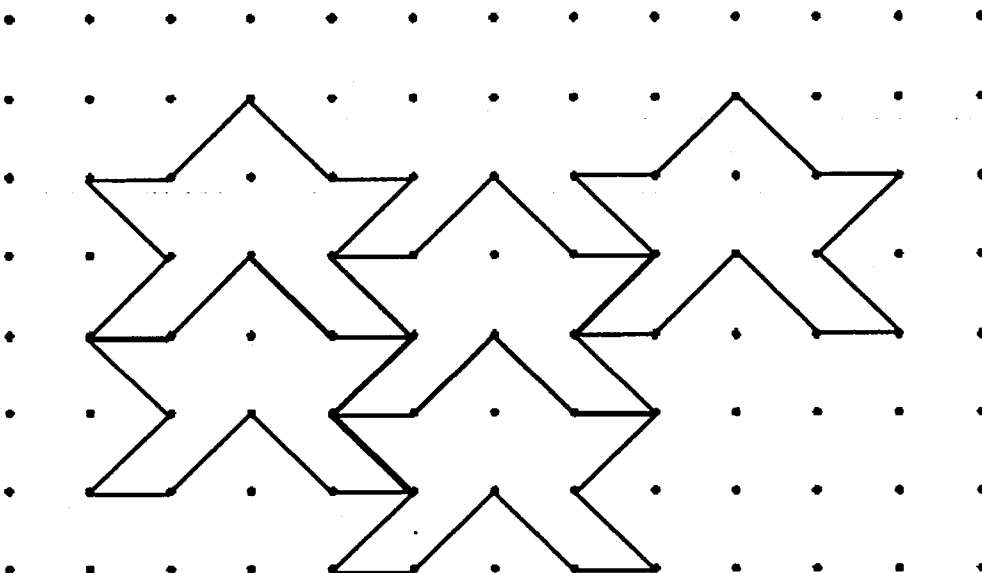

21. In City A, every household has either one or two computers.
The ratio of the number of households to the number of computers is 3 : 5.
What fraction of the households has only one computer?

Ans: _____

22. Express 43.02 as a fraction in its simplest form.

Ans: _____

23. Find the value of 0.36×7 .

Ans: _____

24. Round off 76.959 to 1 decimal place.

Ans: _____

25. There are 12 tables, 11 chairs and 5 stools.
What is the ratio of the number of tables to the total number of chairs and stools?

Ans: _____

Questions 26 to 30 carry 2 marks each. Show your working clearly in the space provided for each question and write your answers in the space provided. For questions which require units, give your answers in the units stated. All diagrams are not drawn to scale. Answers in fractions or ratio must be expressed in the simplest form.

26. 55 lamp posts were placed equally along a street.
The distance between the first and the fourth lamp post was 36 m.
Find the total distance from the first lamp post to the 55th lamp post.

Ans: _____ m

27. Fill in the blank with the correct mathematical symbol (+, -, ×, or ÷) to make the statement below true.

25. $3 + 15 \div 5 + 7 = 85$

Ans: _____

28. The length of Cube A is 3 times that of Cube B.
What is the ratio of the volume of Cube A to the volume of Cube B?

Ans: _____

29. Kim packed $\frac{3}{5}$ kg of sugar into 6 similar bags.
How many kilograms of sugar was there in each bag?

Ans: _____ kg

30. Ali, Beng and Tom shared a sum of money.
Ali and Beng received the same amount of money.
The ratio of the total amount of money Ali and Beng had to the total amount of money Beng and Tom had was 4 : 9.
What fraction of the sum of money had Tom?

Ans: _____

-End of Paper-
Please check your work carefully ☺

Setters: Mrs Tan Chwee Piow, Miss Lim Li Shan, Mr Teo Wee Toon



RAFFLES GIRLS' PRIMARY SCHOOL

SEMESTRAL ASSESSMENT 1 2009 Paper 2

Your Score Out of 60 marks		
	Banded Class	Level
Highest score		
Average score		
Parent's Signature		

Name : _____ () Class: P5__
Banded Class: P5__

12 May 2009 MATHEMATICS Att: 1 h 40 min

You are allowed to use a calculator for this paper.

Questions 1 to 5 carry 2 marks each. Show your working clearly in the space provided for each question and write your answers in the spaces provided. For questions which require units, give your answers in the units stated. (10 marks)

1. $\frac{2}{5}$ of a piece of string is 40 cm long.

How long is $\frac{1}{4}$ of the string? (Give your answer in centimetres)

Ans: _____ cm [2]

2. A box can hold 64 tennis balls.
The same box can hold 58 more balls if it is filled with ping pong balls instead.
How many ping pong balls can 26 such boxes hold?

Ans: _____ [2]

3. A rectangular fish tank measures 45 cm long, 10 cm wide and 25 cm high.
It is filled with water to the depth of 15 cm.
How much more water is needed to fill the fish tank completely?

Ans: _____ cm³ [2]

4. Ahmad is $1\frac{1}{2}$ times as old as Ming. Owen's age is $\frac{1}{2}$ of Ming's age.
Express the ratio of Ahmad's age to Ming's age to Owen's age in the simplest form?

Ans: _____ [2]

5. The area of the rectangle ABCD below is 140 cm^2 .
Area of $\triangle XYD$ is 20 cm^2 .
Find the total shaded area of the rectangle.

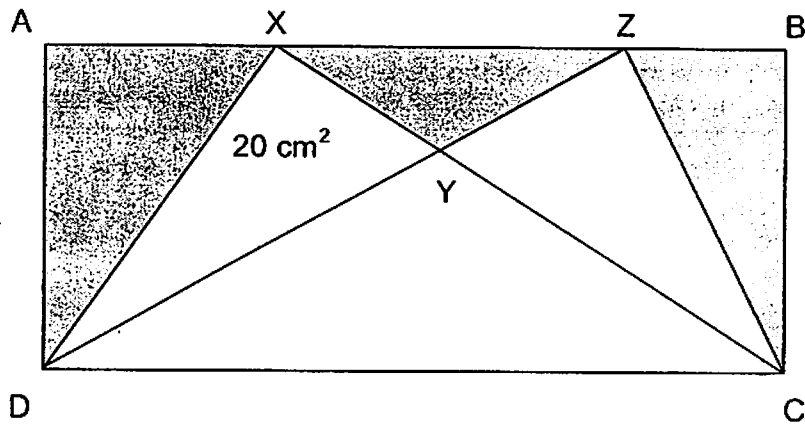

Ans: _____ cm^2 [2]

For questions 6 to 18, show your working clearly in the space provided for each question and write your answers in the spaces provided. The number of marks available is shown in the brackets [] at the end of each question or part-question. (50 marks)

6. The ratio of John's pencil to Mary's pencil was 4 : 3.
After John transferred 80 pencils to Mary, the ratio was 4 : 7.
How many pencils did they have altogether?

Ans: _____ [3]

7. There were 280 people at a concert.
 $\frac{1}{4}$ of the males and $\frac{1}{5}$ of the females wore glasses.
Given that a total of 60 people wore glasses in the concert, how many females wore glasses?

Ans: _____ [3]

8. Five pieces of wooden blocks, each 15 cm thick, were nailed together to form a rectangular container as shown below.
Find the capacity of the container. (Express your answer in litres)

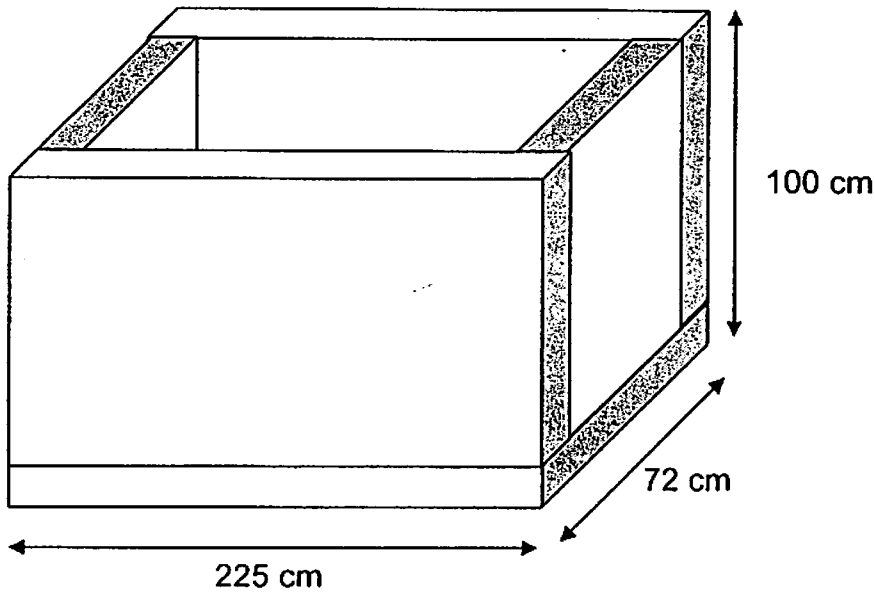

Ans: _____ [3]

9. In the figure below, ABCD is a rectangle.
 AB is 44 cm long and BC is 30 cm wide.
 AXC and BXD are straight lines where $AX=XC$ and $BX = XD$.
 Express the total unshaded area as a fraction of the total shaded area.

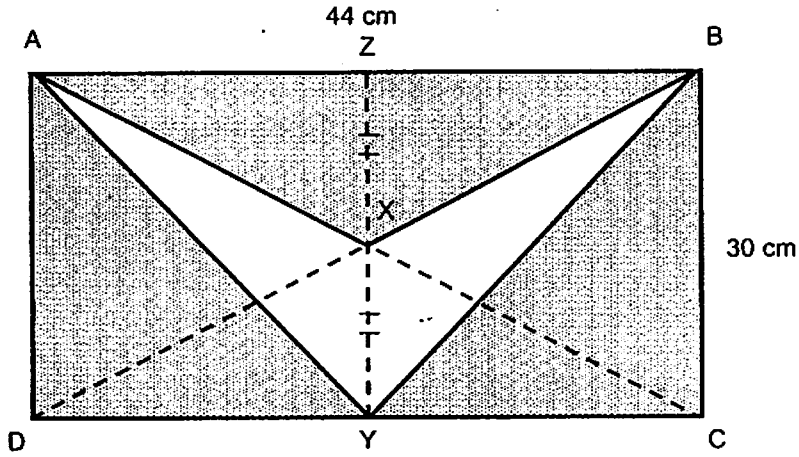

Ans: _____ [3]

10. A rectangular water tank which was 80 cm long, 40 cm wide and 60 cm tall was $\frac{11}{12}$ filled with water.

When a metal cube of sides 30 cm was completely submerged into the tank, the water level in the tank rose to the brim and some water was spilled over. Find the amount of water that was spilled over.

Ans: _____ [3]

11. Jack, Tim and Harry had a total of 5200 stamps.
Tim had thrice as many stamps as Harry.
Harry had 800 stamps fewer than Jack.
How many stamps had Tim?

Ans: _____ [4]

12. Two identical right-angled triangles overlapped each other as shown in the diagram below.
Find the area of the shaded part.

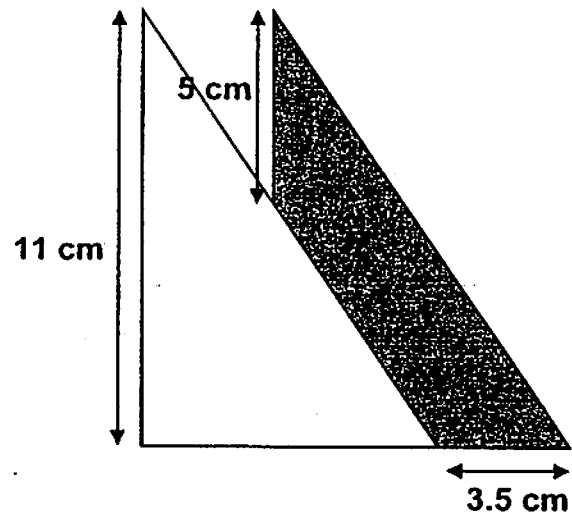

Ans: _____ [4]

22

13. Sami saves 40 pieces of \$2-note and \$10-note.
Her total savings is \$168.
How many pieces of \$2-note does Sami save?

Ans: _____ [3]

14. The table below shows the carpark charges in Wallerton Carpark.

Day and Time	Carpark Charges
Monday to Saturday Before 6 p.m.	\$1.20 for the first hour \$1.00 for every subsequent hour or part thereof
Monday to Saturday After 6 p.m.	\$1.50 for the first hour \$1.30 for every subsequent hour or part thereof
Sunday	\$2.00 per entry from 7 a.m. to 7 a.m. the following day

Mr Koo parked his car from Saturday afternoon 3.30 p.m. to Monday morning 8.30 a.m.

How much would be the carpark charges?

Ans: _____ [5]

15. Study the diagram and the table below.

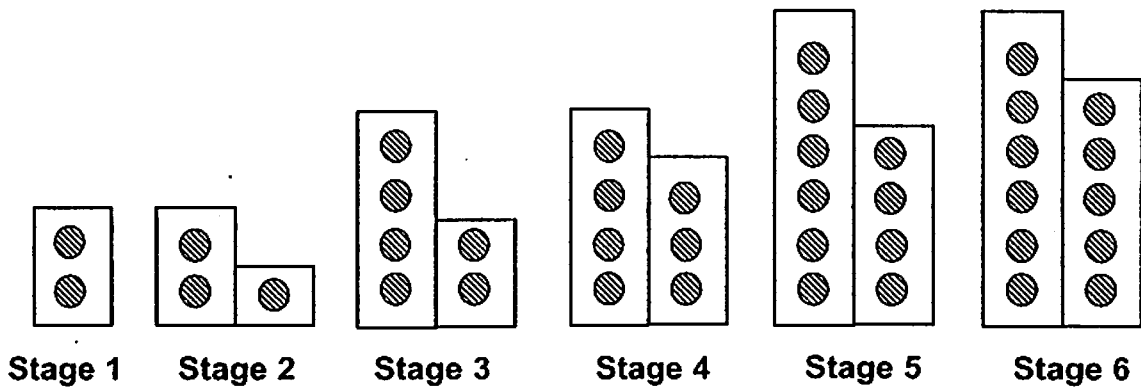

Stage	1	2	3	4	5	6
Number of Dots	2	3	6	7	10	11

- Find the number of dots in stage 7.
- Find the number of dots in stage 24.
- At which stage will there be 99 dots?

Ans: a) _____ [1]

b) _____ [2]

c) _____ [2]

16. The entrance fees to the zoo is as follow:

Adult: \$18
Child: \$9

Group package tickets for 2 adults and 3 children are sold at a discounted amount of \$55 only.

On a given day, 1422 adults and 2598 children visited the zoo.

What is the minimum amount of entrance fees that the zoo can collect on that given day?

Ans: _____ [5]

17. In 2008, there were 882 pupils in Greenwood Primary School and $\frac{1}{3}$ of them were girls.

After merging with Blackforest Girls' School in 2009, $\frac{3}{4}$ of the pupils in the merged school are now girls.

How many girls were from Blackforest Girls' School?

Ans: _____ [5]

18. The number of marbles in Box A, Box B and Box C was 195.
John added 60 marbles to those in Box A, doubled the number of marbles in Box B and halved the number of marbles in Box C.
The ratio of the number of marbles becomes 4 : 1 : 2.
What is the total number of marbles in the three boxes now?

Ans: _____ [4]

-End of Paper-
Please check your work carefully ☺

Setters: Mrs Tan Chwee Piow, Miss Lim Li Shan, Mr Teo Wee Toon

28

2009 P5 Mathematics SA1 (Paper 1)

Section A

1 mark questions (x10)

2 marks questions (x5)

No.	Answer	No.	Answer	No.	Answer
1	2	6	2	11	4
2	4	7	1	12	2
3	2	8	3	13	2
4	1	9	3	14	1
5	2	10	3	15	3

Section B

Qn 16 to 25 - 1 mark questions

Qn 26 to 30 - 2 marks questions

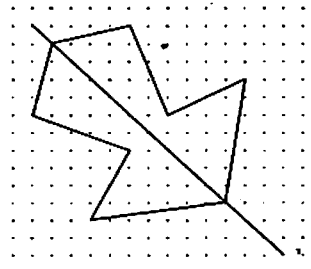
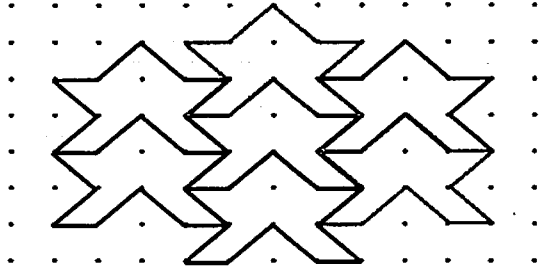

No.	Answer
16	two million and twelve thousand, five hundred and forty-eight
17	$\frac{9}{20}$, 0.352, $\frac{1}{4}$, 0.245
18	3.08
19	
20	
21	$\frac{1}{3}$



No.	Answer
22	$43\frac{1}{50}$
23	2.52
24	77.0
25	3 : 4
26	$36 \div 3 = 12$ $54 \times 12 = 648$ ---M1, A1
27	x ---A2
28	$3 \times 3 \times 3 = 27$ ---M1 27:1 ---A1
29	$\frac{3}{5} \div 6 = \frac{3}{5} \times \frac{1}{6} = \frac{1}{10}$ ---M1, A1 OR $0.6 \div 6 = 0.1$ ---M1, A1
30	Tom \rightarrow 7 units ---M1 $\frac{7}{11}$ ---A1

Note: Award 2 marks if answer is correct in blank provided.
If answer is wrong, look at working and award marks accordingly.

2009 P5 Mathematics SA1 (Paper 2)

1.	$\frac{2}{5} \longrightarrow 40 \text{ cm}$ $\frac{1}{5} \longrightarrow 40 \text{ cm} \div 2 = 20 \text{ cm}$ $\frac{5}{5} \longrightarrow 20 \times 5 = 100 \text{ cm} \quad \text{---M1}$ $\frac{1}{4} \times 100 \text{ cm} = 25 \text{ cm} \quad \text{---A1}$	<p style="text-align: right;">Ans : 25 cm</p>						
2.	$64 + 58 = 122$ $122 \times 26 = 3172 \quad \text{---M1, A1}$	<p style="text-align: right;">Ans: 3172</p>						
3.	$45 \times 10 \times 10 = 4500 \quad \text{---M1, A1}$	<p style="text-align: right;">Ans: 4500 cm³</p>						
4.	<p>Ahmad <table border="1" style="display: inline-table; vertical-align: middle;"><tr><td style="width: 20px; height: 15px;"></td><td style="width: 20px; height: 15px;"></td><td style="width: 20px; height: 15px;"></td></tr></table></p> <p>Ming <table border="1" style="display: inline-table; vertical-align: middle;"><tr><td style="width: 20px; height: 15px;"></td><td style="width: 20px; height: 15px;"></td></tr></table></p> <p>Owen <table border="1" style="display: inline-table; vertical-align: middle;"><tr><td style="width: 20px; height: 15px;"></td></tr></table> ---M1,A1</p>							<p style="text-align: right;">Ans: 3 : 2 : 1</p>
5.	$140 \div 2 = 70 \quad \text{---M1}$ $70 + 20 = 90$ $140 - 90 = 50 \quad \text{---A1}$ <u>ALTERNATIVE METHOD</u> $140 \div 2 = 70 \quad \text{---M1}$ $70 - 20 = 50 \quad \text{---A1}$	<p style="text-align: right;">Ans: 50 cm²</p>						
6.	$4 : 3 \qquad 4 : 7$ $44 : 33 \qquad 28 : 49$ $44 - 28 = 16$ 16 units $\rightarrow 80$ 1 unit $\rightarrow 80 \div 16 = 5 \quad \text{--- M1}$ 77 units $\rightarrow 5 \times 77 = 385 \quad \text{--- M1, A1}$	<p style="text-align: right;">Ans: 385</p>						

7.	<p>MALE </p> <p>FEMALE </p> <p>60</p> <p>$60 \times 4 = 240$ ---M1</p> <p>$280 - 240 = 40$ ---M1,A1</p> <p style="text-align: right;">Ans: 40</p>
8.	<p>$195 \times 42 \times 85 = 696\ 150$ ---M1, A1</p> <p>$696\ 150\ \text{cm}^3 = 696.15\ \text{l}$ ---A1</p> <p style="text-align: right;">Ans: 696.15 l</p>
9.	<p>Area of Rectangle \rightarrow 1 whole</p> <p>Unshaded area $\rightarrow \frac{1}{4}$ ---- M1</p> <p>Shaded area $\rightarrow 1 - \frac{1}{4} = \frac{3}{4}$ ---- M1</p> <p>Unshaded area as a fraction of the shaded area $\rightarrow \frac{1}{3}$ ---- A1</p> <p style="text-align: right;">Ans: $\frac{1}{3}$</p> <p><u>ALTERNATIVE METHOD</u></p> <p>Shaded Area $\rightarrow \frac{1}{2} \times 44 \times (30 + 2) + 2 \times \frac{1}{2} \times 30 \times (44 + 2)$</p> <p style="padding-left: 40px;">$= 330 + 660$</p> <p style="padding-left: 40px;">$= 990$ --- M1</p> <p>Unshaded Area $\rightarrow 44 \times 30 - 990 = 330$ ---M1</p> <p>Unshaded area as a fraction of the shaded area $\rightarrow \frac{1}{3}$ ---- A1</p>

10.	<p>Volume of empty space in the tank</p> <p>$\rightarrow 80 \text{ cm} \times 40 \text{ cm} \times 60 \text{ cm} \times \left(1 - \frac{11}{12}\right) = 16\,000 \text{ cm}^3$ --M1</p> <p>Volume of the metal cube $\rightarrow 30 \text{ cm} \times 30 \text{ cm} \times 30 \text{ cm} = 27\,000 \text{ cm}^3$</p> <p>Volume of the spill over $\rightarrow 27\,000 - 16\,000 = 11\,000 \text{ cm}^3$ --M1,A1</p> <p style="text-align: right;">Ans: 11 000 cm³</p>
11.	<p>Tim </p> <p>Harry </p> <p>Jack </p> <p style="text-align: center; margin-left: 150px;">800</p> <p style="text-align: right; margin-right: 50px;">} 5200</p> <p>5 units $\rightarrow 5200 - 800 = 4400$ --M1</p> <p>1 unit $\rightarrow \frac{4400}{5} = 880$ --M1</p> <p>3 units $\rightarrow 880 \times 3 = 2640$ --M1,A1</p> <p style="text-align: right;">Ans: 2640</p>
12.	<p>$\frac{1}{2} \times 5 \times 3.5 = 8.75$ --M1</p> <p>$3.5 \times 6 = 21$ -- M1</p> <p>$21 + 8.75 = 29.75$ --- M1,A1</p> <p style="text-align: right;">Ans: 29.75 cm²</p>

13. Assume all \$10 notes

$$40 \times 10 = 400$$

$$400 - 168 = 232$$

--- M1

$$10 - 2 = 8$$

$$232 \div 8 = 29$$

---- M1, A1

Ans: 29 \$2 notes

ALTERNATIVE METHOD (Guess and Check)

No. of \$2 notes	No. of \$10 notes	Total savings
20	20	$(20 \times 2) + (20 \times 10) = 240$
30	10	$(30 \times 2) + (10 \times 10) = 160$
29	11	$(29 \times 2) + (11 \times 10) = 168$

Evident on:

- 1) Correct total number of notes, ie add up to 40 pieces --- M1
- 2) Correct operation involved to check the answer, ie multiply by the number of notes and add up --- M1
- 3) Correct answers --- A1

14. Saturday

From 3.30pm to 4.30pm → 1.20

4.30pm to 5.30pm → 1

5.30pm to 6pm → 1

} M1

6pm to 7pm → 1.50

7pm-7am → $1.30 \times 12 = 15.60$

} M1

Sunday

7am to 7am next day → 2

Monday

7am to 8am → 1.20

8am to 8.30am → 1

} M1

Total Cost → $1.20 + 1 + 1 + 1.50 + 15.60 + 2 + 1.20 + 1 = 24.50$ ----- M1, A1

Ans: \$24.50

15.	<p>a) $11 + 3 = 14$ ---M1</p> <p>b) Note: For odd stages: number of dots = stage no. \times 2 For even stages: number of dots = stage no. \times 2 -1 For stage 24: $24 \times 2 - 1 = 47$ -----M1, A1</p> <p>c) 99 dots means the stage no. is even. Work backwards: $(99 + 1) \div 2 = 50$ -----M1, A1</p> <p style="text-align: right;">Ans: (a) 14 dots (b)47 dots (c)Stage 50</p>
16.	<p>Maximum pairs of adults $\rightarrow 1422 \div 2 = 711$ --- M1 Maximum no. of children that can form package groups with these adults $\rightarrow 711 \times 3 = 2133$</p> <p>Maximum no. of package groups $\rightarrow 711$</p> <p>Amount of fees from these family groups $\rightarrow 711 \times \\$55 = \\$39\,105$ --- M1</p> <p>Amount of fees from the remaining children $\rightarrow (2598 - 2133) \times \\$9 = \\$4185$ --- M1</p> <p>Possible minimum amount of entrance fees collected $\rightarrow \\$39\,105 + \\$4185 = \\$43\,290$ --- M1, A1</p> <p style="text-align: right;">Ans: \$43 290</p>

17.

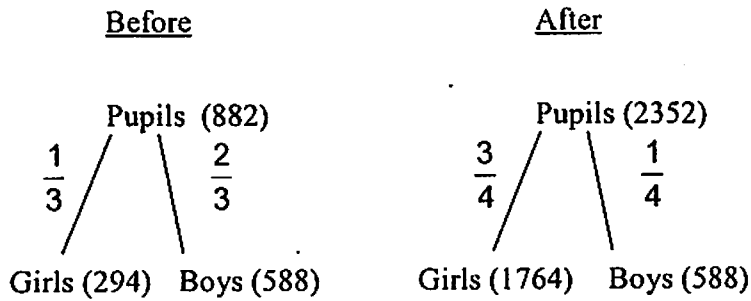

No. of Girls in Greenwood Primary School $\rightarrow 882 \div 3 = 294$
 No. of Boys in Greenwood Primary School $\rightarrow 882 - 294 = 588$ ---M1
 No. of pupils in the merged school $\rightarrow 588 \times 4 = 2352$ ---M1
 No. of girls in the merged school $\rightarrow 2352 - 588 = 1764$ ---M1
 No. of girls from Blackforest Girls' School $\rightarrow 1764 - 294 = 1470$ ---M1, A1
Ans: 1470

18.

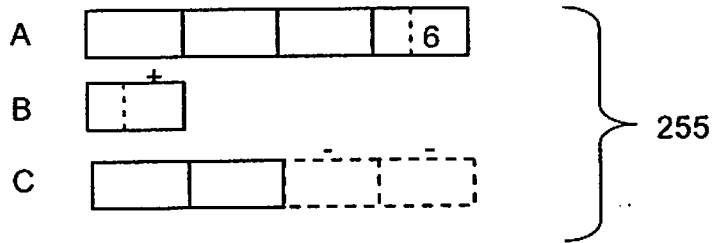

$195 + 60 = 255$ ----- M1
 17 units $\rightarrow 255$
 1 unit $\rightarrow 255 \div 17 = 15$ ----- M1
 14 units $\rightarrow 14 \times 15 = 210$ ----- M1, A1

Ans: 210 marbles