



RAFFLES GIRLS' PRIMARY SCHOOL
Preliminary Examinations 2009
Mathematics
Primary 6

Name : _____ ()

Class: P6 _____ Banded Class: P6 _____ Date: 26 August 2009

Your Score out of 100 marks	/100	
	Math Class	Level
Highest Score		
Average Score		
Parent's Signature		

Paper 1 (Sections A and B)
Duration: 50 minutes

INSTRUCTIONS TO CANDIDATES

1. Do not turn over this page until you are told to do so.
2. Follow all instructions carefully.
3. Answer all questions.
4. Shade your answers in the Optical Answer Sheet (OAS) provided.
5. You are not allowed to use a calculator.

Total Paper 1	/ 40
----------------------	-------------

SECTION A (20 marks)

Questions 1 to 10 carry 1 mark each. Questions 11 to 15 carry 2 marks each. For each question, four options are given. One of them is the correct answer. Make your choice (1, 2, 3 or 4). Shade your answer (1, 2, 3 or 4) on the OAS provided. All diagrams are not drawn to scale. No calculators may be used for this paper

1. What is the value of the digit 8 in 2 876 500?

- (1) 8 000
- (2) 80 000
- (3) 800 000
- (4) 8 000 000

2. John left Town A at 10 a.m. He cycled at 15 km/h and reached Town B at 1 p.m. How far was Town A from Town B?

- (1) 15 km
- (2) 30 km
- (3) 45 km
- (4) 60 km

3. Express $2\frac{1}{5}$ hours in minutes.

- (1) 132 min
- (2) 135 min
- (3) 140 min
- (4) 220 min

4. Observe the following pattern.



Fill in the blank with a suitable picture.



5. The length of a rectangle is thrice as long as its breadth.
Find the perimeter of the rectangle if the length is 6 cm long.

- (1) 12 cm
- (2) 16 cm
- (3) 24 cm
- (4) 48 cm

6. During the recent school concert, the number of pupils who attended was 1 680 when rounded off to the nearest tens.
Which of the following is a possible number of pupils who attended the concert?

- (1) 1 674
- (2) 1 679
- (3) 1 685
- (4) 1 689

7. A is a number.

$$\frac{7}{8} \times A = \boxed{?} \times A \times \frac{1}{2}$$

What is the missing number in the box?

- (1) $\frac{7}{16}$
- (2) $\frac{1}{2}$
- (3) $1\frac{3}{4}$
- (4) $3\frac{1}{2}$

8. The sum of $\frac{1}{4}$ and $\frac{2}{5}$ is the same as ?

- (1) 0.13
- (2) 0.33
- (3) 0.65
- (4) 0.75

9. What is the reading indicated on the weighing scale below?

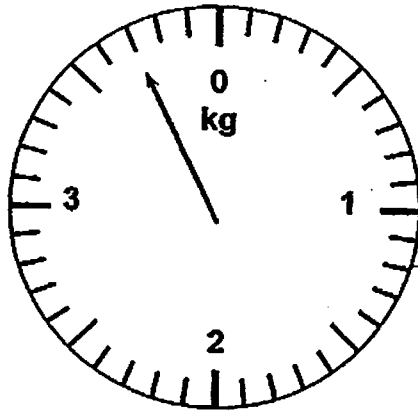

- (1) 3 kg 7 g
(2) 3 kg 70 g
(3) 3 kg 700 g
(4) 3 kg 770 g
10. The radius of a circle is 14 cm. Find the area of the quadrant. (Take $\pi = \frac{22}{7}$)
- (1) 22 cm²
(2) 88 cm²
(3) 154 cm²
(4) 616 cm²
11. Find the value of $\frac{1}{2}\%$ of 200.
- (1) 1
(2) 10
(3) 100
(4) 1000

12. Carol has some clips as shown in the pie chart. The ratio of the number of yellow clips to the number of green clips is 2 : 3.

What percentage of the clips is green?

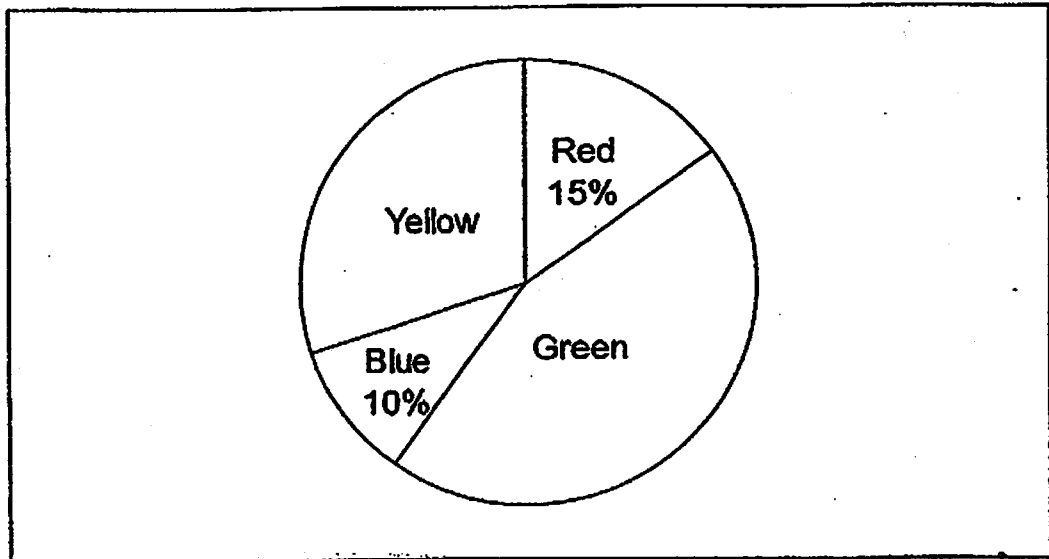

- (1) 25 %
- (2) 30 %
- (3) 45 %
- (4) 50 %

13. $\frac{\clubsuit}{18} = \frac{4}{\blacktriangle} = \frac{5}{15}$

$\frac{\clubsuit}{\blacktriangle} = \boxed{?}$

What is the missing fraction in its simplest form?

(1) $\frac{2}{9}$

(2) $\frac{1}{3}$

(3) $\frac{3}{7}$

(4) $\frac{1}{2}$

14. Express 130 tenths and 38 thousandths as a decimal.

(1) 13.38

(2) 13.038

(3) 130.038

(4) 130.38

15. There are some turkeys, chickens and ducks in a farm. $\frac{2}{5}$ of the animals are turkeys, the rest are chickens and ducks. The ratio of the number of chickens to the number of ducks is 7 : 8.

If there are 20 more turkeys than ducks, how many turkeys are there?

(1) 70

(2) 80

(3) 100

(4) 250

SECTION B (20 marks)

Questions 16 to 25 carry 1 mark each. Questions 26 to 30 carry 2 marks each. Write your answers in the spaces provided. For questions which require units, give your answers in the units stated. All diagrams are not drawn to scale. Answers in fractions or ratio must be expressed in the simplest form.

16. Arrange the following numbers in ascending order.

3.321 3.132 3.231 3.123

Ans: _____

17. Each sticker cost 30 cents. Jane bought p stickers and gave the cashier a 5 dollar note. How much change should she receive?

Ans: \$ _____

18. What is the missing number in the box?

$$15 \div \frac{1}{\Delta} = 75$$

$$3 \div \frac{1}{\Delta} = \boxed{?}$$

Ans: _____

19. A movie marathon started at 9.30 p.m. and ended at 5.35 a.m. the next day.
How long was the movie marathon in hours and minutes?

Ans: _____ h _____ min

20. ABCD is a square.
X is the mid-point of AB.
Y is the mid-point of BC.
What fraction of the square is shaded?

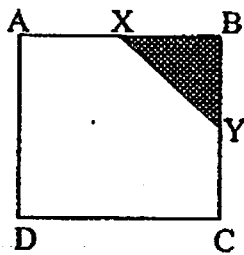

Ans: _____

21. The line graph below shows the monthly sales at a shop in a shopping mall from January to May this year. Between which 2 consecutive months was there a 200% increase in sales?

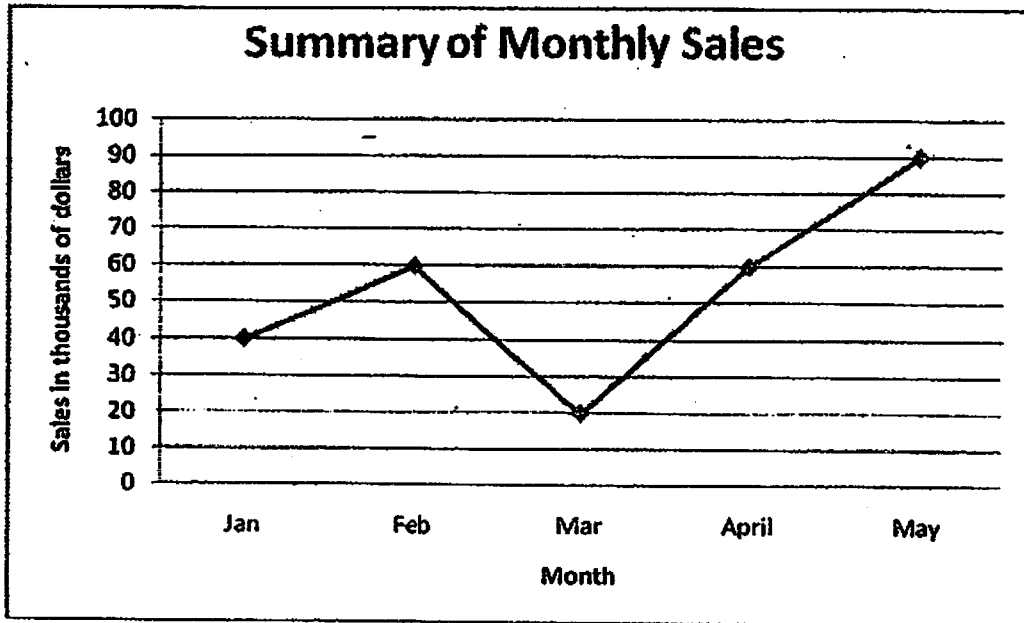

Ans: _____ and _____

22. The net of a cube is shown below.

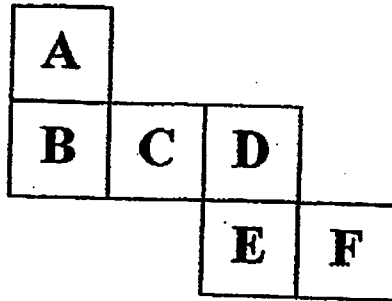

If face C is on the top of the cube, which face is at the base of the cube?

Ans: _____

23. The figure below shows a cuboid which is made of some identical unit cubes. When the three shaded cubes are removed and the remaining cubes are painted red, including the base of the cuboid, how many unit cubes will have only one face painted red?

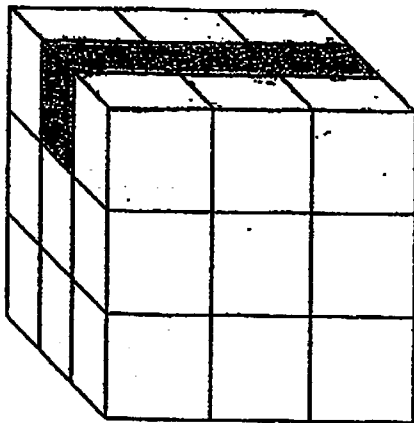

Ans: _____

24. ABCD is a trapezium and BCD is an equilateral triangle. Find $\angle ADB$.

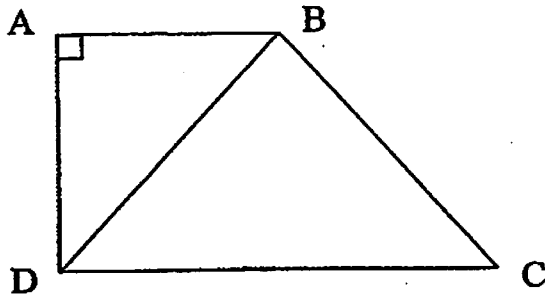

Ans: _____°

25. $\frac{3}{8}$ of Jenny's money is as much as $\frac{2}{5}$ of Kiren's money.

Express Jenny's money as a ratio of Kiren's money.

Ans: _____

26. In a fruit market, cherries were sold at \$3.20 for 100g. How much did Jane pay for $10\frac{1}{5}$ kg of cherries?

Ans: \$ _____

27. A cuboid measuring 12 cm by 9 cm by 2 cm has the same volume as a cube. Find the length of the cube.

Ans: _____ cm

28. A and B are 2 different whole numbers, and A is less than B. Given that $A + B = 6$ and $\frac{5}{6} + A = \frac{1}{6} \times B$, express $A + B$ as a fraction.

Ans: _____

29. Devi has $\frac{2}{5}$ as many stamps as Ellen.

Express the number of stamps Ellen has as a percentage of Devi's number of stamps.

Ans: _____ %

30. Jane took part in a triathlon where she had to swim, cycle and run.

She swam 200 metres, cycled for $1\frac{1}{2}$ hours and ran 1.8 km to reach the finishing line. If the total distance for the race was 20 km, what was her cycling speed?

Ans: _____ km/h



RAFFLES GIRLS' PRIMARY SCHOOL
Preliminary Examinations 2009
Mathematics
Primary 6

Name : _____ ()

Class: P6 _____

Banded Class: P6 _____

Date: 26 August 2009

Paper 2 (Sections A and B)
Duration: 1 hour 40 minutes

INSTRUCTIONS TO CANDIDATES

1. Do not turn over this page until you are told to do so.
2. Follow all instructions carefully.
3. Answer all questions.
4. Write your answers in this booklet.
Show your working clearly as marks are awarded for correct working.
5. You are allowed to use a calculator.

Paper 2	Marks
Paper 2 Section A	/ 10
Paper 2 Section B	/ 50
Total Paper 2	/ 60

Section A

Questions 1 to 5 carry 2 marks each. Show your working clearly in the space provided for each question and write your answers in the spaces provided. For questions which require units, give your answers in the units stated. [10 marks]

1. Find the value of each of the following expressions when $y = 6$.

(a) $3y - 4$

(b) $y + \frac{2y}{3}$

Ans: (a) _____ [1]

(b) _____ [1]

2. A dress cost \$139.95. During a sale, a 20% discount was given. Calculate the sale price of the dress.



Ans: \$ _____

3. When a number is divided by 8, the quotient is 121 with no remainder.
What is the remainder when the same number is divided by 9?

Ans: _____

4. Find the number that is exactly between $\frac{4}{5}$ and $1\frac{1}{3}$.

Ans: _____

5. BC is one side of a parallelogram.
Complete the figure ABCD such that $AB = 5 \text{ cm}$ and $\angle BAD = 120^\circ$.

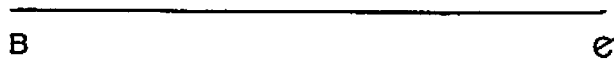

Section B

For questions 6 to 18, show your working clearly in the space provided for each question and write your answers in the spaces provided. The number of marks available is shown in brackets [] at the end of each question or part question. [50 marks]

6. Alice, Beth and Claire had 600 stamps altogether. After Beth had given 30 stamps to Alice, Beth had twice as many stamps as Claire and Alice had 20 stamps more than Claire. How many stamps did Claire have?

Ans: _____ [3]

7. Last year the total age of Mr Tan and his wife is p years old.
His wife is 1 year younger than him.
What is his wife's age 2 years from now? Express your answer in terms of p .

Ans: _____ [3]

8. In the figure below, O is the centre of a circle where OCD is an equilateral triangle.

Given that $\angle OAB = 20^\circ$ and $\angle AOD = 127^\circ$. Find $\angle BOC$.

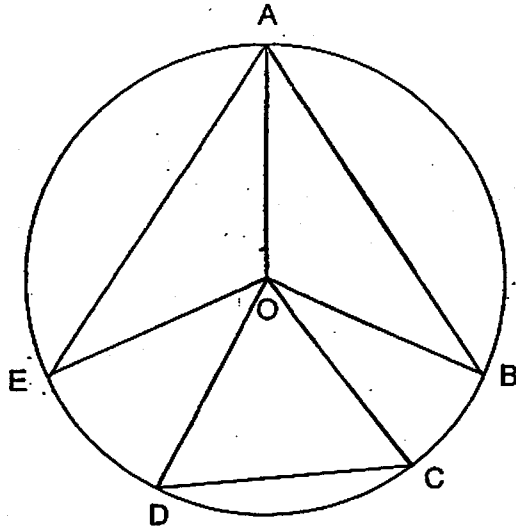

Ans: _____ [3]

9. Tricia has some pink, red and yellow ribbons.

$\frac{1}{3}$ of them are pink ribbons.

Four fewer than $\frac{1}{3}$ of the remainder are red ribbons.

The remaining 24 are yellow ribbons.

How many pink ribbons does Tricia have?

Ans: _____ [3]

10. Some secondary one boys were asked to name their favourite sport. Their choices were represented on the pie chart below.

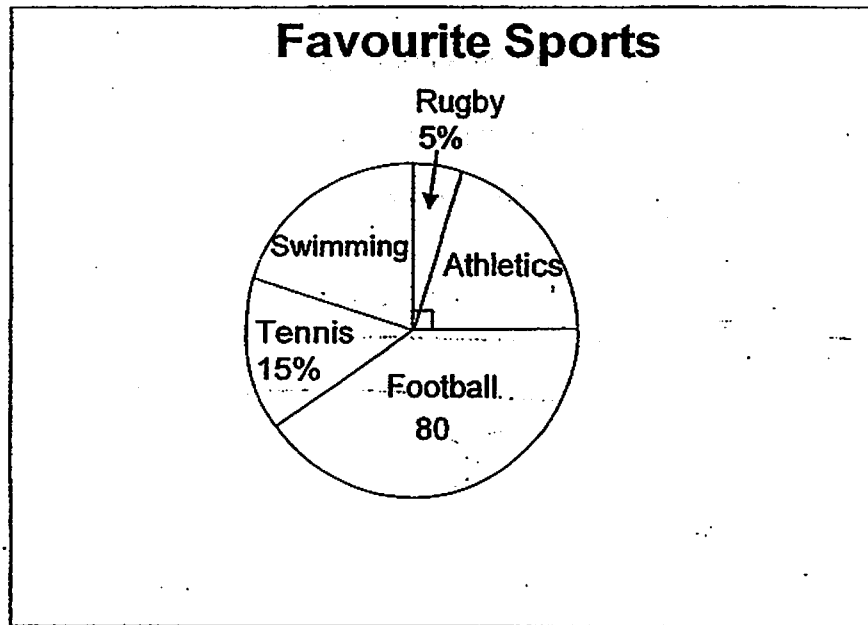

There was an equal number of boys who liked athletics and swimming. 80 boys chose football as their favourite sport.

- (a) What fraction of the boys liked swimming?
(b) Find the total number of secondary one pupils who took part in the survey.

Ans: (a) _____ [1]

(b) _____ [2]

11. Mrs Kee baked some cookies and packed all the cookies in 12 small boxes and 5 big boxes.

There were equal number of cookies in each small box and equal number of cookies in each big box.

Each big box contained 14 more cookies than each small box. $\frac{18}{29}$ of the cookies baked were packed in small boxes.

How many cookies were there in each small box?

Ans: _____ [4]

12. Tap A, Tap B, Tap C and an empty rectangle tank are shown below.

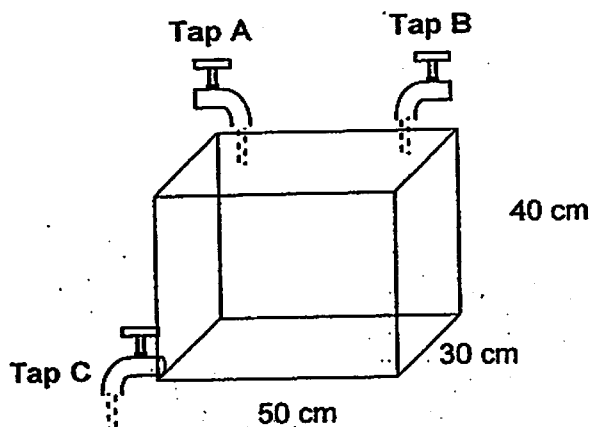

Lily turned on Tap A with water flowing at a rate of 5 litres per minute.

After 2 minutes, she placed a rock of volume 1250 cm^3 in the tank and turned on Tap B and Tap C as well.

Tap C drains the tank at the rate of 2 litres per minute.

After 5 more minutes, Lily turned off all the taps and noted that the height of the water level was 30 cm.

Find the rate of the flow of water from Tap B.

Ans: _____

[4]

13. The figure below is made up of a big circle, square and a small circle.
The area of the square is 400cm^2 .
Find the area of the shaded region.
(Correct your answer to 2 decimal places)

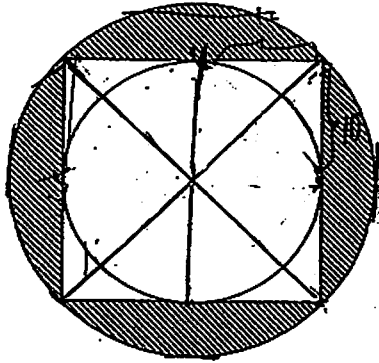

Ans: _____ [4]

14. John shifted the decimal point of a number twice to the left to obtain a new number. The difference between the new number and the original number was 136.62.

(a) How many times of the new number is the original number?

(b) What is the sum of the 2 numbers?

Ans: (a) _____ [1]

(b) _____ [3]

15. The equilateral triangles below are formed using 2 cm sticks.

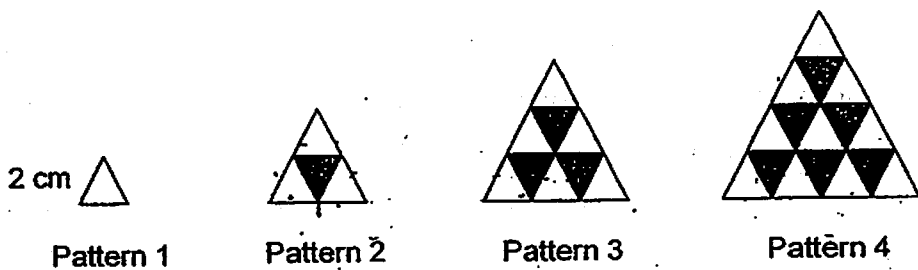

- (a) How many sticks are needed to form pattern 5?
- (b) In which pattern will the ~~each~~^{side} of the triangle measure 30 cm?
- (c) Calculate the number of shaded triangles in Pattern 100.

Ans: (a) _____ [1]
 (b) _____ [1]
 (c) _____ [2]

16. There were some sweets in Boxes X, Y and Z.

Box X contained 20% of the total number of sweets in Boxes X, Y and Z.

The ratio of the number of sweets in Box Y to the total number of sweets in Boxes X and Z is 2 : 1.

If there are 24 more sweets in Box Y than Box Z, find the total number of sweets in Boxes X, Y and Z.

Ans: _____ [5]

17. At 9.30 a.m., Train A which was 200 m long, pulled out of Nanas Station and travelled towards Dadas Station at a uniform speed of 80 km/h. Half an hour later, Train B which was 150 m long, left Dadas Station and travelled towards Nanas Station at a uniform speed of 90 km/h.

- (a) How far has Train A travelled when Train B left Dadas Station?
- (b) The two trains met each other in a tunnel. Both trains took 15 minutes completely out of the tunnel. Calculate the length of the tunnel.

Ans: (a) _____ [1]

(b) _____ [4]

18. At first, 25% of Kumar's money was the same as $33\frac{1}{3}\%$ of Lily's money.

Lily's father gave her \$80 later, while Kumar spent \$325.

In the end, Lily had $2\frac{1}{2}$ times as much money as Kumar.

(a) How much money did Kumar have at first?

(b) How much money did Lily have in the end?

Ans: (a) _____ [3]

(b) _____ [2]

- End of Paper -

Raffle Girls Primary School
RGPS P6 Prelims (09) Answer – Paper 1

Questions 1 to 10 carry 1 mark each. Questions 11 to 15 carry 2 marks each.

- | | | | |
|----|---|-----|---|
| 1. | 3 | 9. | 3 |
| 2. | 3 | 10. | 3 |
| 3. | 1 | 11. | 1 |
| 4. | 2 | 12. | 3 |
| 5. | 2 | 13. | 4 |
| 6. | 2 | 14. | 2 |
| 7. | 3 | 15. | 3 |
| 8. | 3 | | |

Questions 16 to 25 carry 1 mark each. Questions 26 to 30 carry 2 marks each.

16. 3.123 3.132 3.231 3.321

17. p stickers ----- $\$0.30 \times p = \$0.30p$

Change ----- $\$5 - \$0.30p$

$$= \$ (5 - 0.30p) \quad (A1)$$

18. 15

19. 8h 5 min

20. $\frac{1}{8}$

21. March and April

22. Face F

23. 4

24. 30°

25. $\frac{3}{8}$ of Jenny = $\frac{2}{5}$ of Kiren

$$\frac{6}{16} \text{ of Jenny} = \frac{6}{15} \text{ of Kiren}$$

Ans: 16 : 15

26. $102 \times \$3.20 = \326.40 (M1, A1)

27. $12 \text{ cm} \times 9 \text{ cm} \times 2 \text{ cm} = 216 \text{ cm}^3$ (M1)

Length of cube $\rightarrow \sqrt[3]{216} = 6 \text{ cm}$ (A1)

28. $\frac{5}{6} \div A = \frac{1}{6} \times B$

$$\frac{5}{6 \times A} = \frac{B}{6}$$

Since $A + B = 6$, then $A = 1$,)

$$B = 5 \text{) M1}$$

Ans: $\frac{1}{5}$ A1

29. $\frac{5}{2} \times 100\% = 250\%$ (M1, A1)

30. $200 \text{ m} = 0.2 \text{ km}$
 $0.2 \text{ km} + 1.8 \text{ km} = 2 \text{ km}$
 $20 \text{ km} - 2 \text{ km} = 18 \text{ km}$

$$18 \text{ km} \div 1\frac{1}{2} = 12 \text{ km/h (M1, A1)}$$

P6 Prelims 2009 Paper 2 Answer

1. (a) 14 (b) 10

2. $0.8 \times 139.95 = 111.96$ (M1 A1)

3. $121 \times 8 = 968$

$968 \div 9 = 107 \text{ r } 5$ (M1 A1)

4. $\frac{4}{5} = \frac{12}{15}; 1\frac{1}{3} = \frac{4}{3} = \frac{20}{15}$ [M1]

$\frac{12}{15}, \frac{13}{15}, \frac{14}{15}, \frac{15}{15}, \frac{16}{15}, \frac{17}{15}, \frac{18}{15}, \frac{19}{15}, \frac{20}{15}$ [A1]

Alternative solution:

$\frac{4}{5} + 1\frac{1}{3} = 2\frac{2}{15}$

$2\frac{2}{15} \div 2 = 1\frac{1}{15}$ M1A1

5. construction

6. Beth – 2 units

Claire – 1 unit

Alice – 1 unit + 20

$600 - 20 = 580$ M1

$580 \div 4 = 145$ M1A1

7. last yr, $2u + 1 = p$

Wife $-\frac{p-1}{2}$ M1

2 years from now $\frac{p-1}{2} + 1 + 2 = \frac{p-1}{2} + 3$ M1 A1

total age two years from now

$p + 2 + 2 + 2 = p + 6$ M1

wife $-\frac{p+6-1}{2} = \frac{p+5}{2}$ M1A1

$\frac{p-1}{2} + 3 = \frac{p-1}{2} + \frac{6}{2}$
 $= \frac{p-1+6}{2} = \frac{p+5}{2}$

$(\frac{p-1}{2} + 3)$ years

8. $180 - 40 = 140$ M1

$360 - 127 - 140 - 60 = 33$ M1 A1

9.

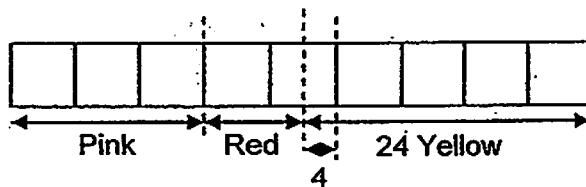

$24 - 4 = 20$

4 units \rightarrow 20 [M1]

1 unit \rightarrow 5

3 units \rightarrow 15 [M1, A1]

10. (a) $25\% - 5\% = 20\%$
 $20/100 = 1/5$ [A1]

(b) $100\% - 15 - 25 - 20 = 40$

40% \rightarrow 80 [M1]

100% \rightarrow 200 pupils [A1]

11. 12 small boxes $\rightarrow \frac{18}{29}$ of the cookies

5 big boxes $\rightarrow \frac{11}{29}$ of the cookies

$\frac{18}{29} \div 12 \rightarrow \frac{3}{58}$ [M1]

$\frac{11}{29} \div 5 \rightarrow \frac{11}{145}$

$\frac{11}{145} - \frac{3}{58} = \frac{7}{290} \rightarrow 14$ cookies [M1]

$$\frac{1}{290} \rightarrow 2 \text{ cookies}$$

$$\frac{3}{58} = \frac{15}{290} \rightarrow 30 \text{ cookies} \quad [\text{M1}, \text{A1}]$$

Alternative 1:

$$\frac{18}{29} \div 12 \rightarrow \frac{3}{58} \quad [\text{M1}]$$

$$\frac{3}{58} \times 5 = \frac{15}{58}$$

$$\frac{11}{29} = \frac{22}{58}$$

$$\left. \begin{array}{l} 22 - 15 = 7 \\ 7 \text{ units} \rightarrow 70 \end{array} \right\} [\text{M1}]$$

$$1 \text{ unit} \rightarrow 10$$

$$3 \text{ units} \rightarrow 30 \quad [\text{M1}, \text{A1}]$$

Alternative 2:

$$\frac{18}{12} \quad [\text{M1}] \times 5 = 7.5$$

$$11 - 7.5 = 3.5$$

$$3.5 \text{ units} \rightarrow 70 \quad \left. \vphantom{\frac{18}{12}} \right\} [\text{M1}]$$

$$1 \text{ unit} \rightarrow 20$$

$$1.5 \text{ units} \rightarrow 30 \quad [\text{M1}, \text{A1}]$$

Alternative 3:

$$\frac{18}{29} = \frac{36}{58}$$

$$36 \div 12 = 3 \quad [\text{M1}]$$

$$3 \times 17 = 51$$

$$58 - 51 = 7$$

$$70 \div 7 = 10 \quad \left. \vphantom{\frac{18}{29}} \right\} [\text{M1}]$$

$$36 \times 10 = 360$$

$$360 \div 12 \rightarrow 30 \quad [\text{M1}, \text{A1}]$$

12. Tap A - $7 \times 5 = 35$

Tap C - $2 \times 5 = 10$

$$50 \times 30 \times 30 = 45000$$

$$45000 - 25000 - 1250 = 18750$$

$$18750 \div 5 = 3750 - 3.75 \text{ l/min}$$

13. $\frac{1}{2} \times r \times r = 100$

$$r \times r = 200 \quad \text{M1}$$

$$\pi \times r \times r = 200 \pi \quad \text{M1}$$

$$200\pi - 400 \approx 228.32 \quad \text{M1 A1}$$

14. (a) The original number is 100 times the new number. [A1]

(b) 100 units – 1 unit = 99 units → 136.62 [M1]

1 unit → 1.38

101 units → 139.38 [M1, A1]

15. (a) $3x_1 + 3x_2 + 3x_3 + 3x_4 + 3x_5 = 45$ (A1)

(b) Pattern 15 (A1)

(c) $100 \times 49 = 4900$

$4900 + 50 = 4950$ (M1 A1)

or $(1+2+3+4+\dots+99) = \frac{99 \times 100}{2} = 4950$ M1 A1

Alternative solution 1 for 15 (c)

$100 \times 100 = 10\,000$

$1 + 2 + 3 + \dots + 100 = 5050$

$10\,000 - 5050 = 4950$ (M1, A1)

Alternative solution 2 for 15 (c)

$0.5n^2 - 0.5n = 4950$, where $n = 100$ (M1, A1)

16.

$\frac{X}{1} : \frac{Y+Z}{4}$

(x3)

3 : 12

$\frac{Y}{2} : \frac{X+Z}{1}$

2 : 1

(x5)

10 : 5

→ change ratio to same units in X, Y, Z

→ 15 units in all

[M1]

Combine ratio $\frac{X}{3} : \frac{Y}{10} : \frac{Z}{2}$

8 units → 24 sweets [M1]

1 unit → 3 sweets [M1]

$(3 + 10 + 2) = 15$ units → $15 \times 3 = 45$ sweets [M1, A1]

Alternative solution 1 for 16

$$y : x + z \\ = 2 : 1$$

$$= 66\frac{2}{3} : 33\frac{1}{3} \quad \text{M1}$$

$$z \rightarrow 33\frac{1}{3} - 20 = 13\frac{1}{3}$$

$$y - z \rightarrow 66\frac{2}{3} - 13\frac{1}{3} = 53\frac{1}{3} \quad \text{M1}$$

$$\frac{24}{53\frac{1}{3}} = \frac{9}{20} \quad \text{M1}$$

$$53\frac{1}{3}$$

$$\frac{9}{20} \times 100 = 45 \quad \text{M1, A1}$$

Alternative solution 2 for 16

$$\begin{array}{ll} x : T & y : x + z \\ = 20 : 100 & 2 : 1 \\ = 60 : 300 & 200 : 100 \end{array} \quad \text{M1}$$

$$z \rightarrow 100 - 60 = 40$$

$$200 - 40 = 160 \quad \text{M1}$$

$$1u \rightarrow 24 \div 160 = 0.15 \quad \text{M1}$$

$$0.15 \times 300 = 45 \quad \text{M1, A1}$$

Alternative solution 3 for 16

$$\frac{1}{5} + \frac{2}{3} = \frac{3}{15} + \frac{10}{15} = \frac{13}{15} \quad \text{M1}$$

$$15 - 13 = 2$$

$$\frac{10}{15} - \frac{2}{15} = \frac{8}{15} \quad \text{M1}$$

$$24 \div 8 = 3 \quad \text{M1}$$

$$3 \times 15 = 45 \quad \text{M1, A1}$$

Alternative solution 4 for 16

$$x \rightarrow \frac{1}{5} \text{ of total, } y \rightarrow \frac{2}{3} \text{ of total, } z \rightarrow \frac{2}{15} \quad \text{M1}$$

$$\frac{2}{3} - \frac{2}{15} = \frac{8}{15} \quad \text{M1}$$

$$24 \div 8 = 3 \quad \text{M1}$$

$$3 \times 15 = 45 \quad \text{M1, A1}$$

17. (a) $\frac{1}{2} \times 80 = 40$ (A1)

(b) $\frac{1}{4} \times 80 = 20$ M1

$\frac{1}{4} \times 90 = 22.5$ M1

$$22.5 - 0.15 + 20 - 0.2 = 42.15 \text{ (M1 A1)}$$

OR

(b) $80 + 90 = 170$ (M1: only if there is evidence that 170 is used to multiply by time to find the distance travelled)

$$\frac{1}{4} \times 170 = 42.5 \text{ (M1)}$$

$$42.5 - 0.15 - 0.2 = 42.15 \text{ (M1 A1)}$$

OR

(b) $0.2 \div 80 = \frac{1}{400}$

$$0.15 \div 90 = \frac{1}{600}$$

$$\frac{15}{60} - \frac{1}{400} = \frac{99}{400}$$

$$\frac{15}{60} - \frac{1}{600} = \frac{149}{600}$$

$$\frac{15}{60} - \frac{1}{600} = \frac{149}{600}$$

$$\frac{99}{400} \times 80 = 19.8 \text{ (M1)}$$

$$\frac{149}{600} \times 90 = 22.35 \text{ (M1)}$$

$$19.8 + 22.35 = 42.15 \text{ (M1 A1)}$$

18. At first: kumar \rightarrow 4 units Lily \rightarrow 3 units

In the end:

(a) $20 \text{ units} - \$325 = 6 \text{ units} + \32

$$20 \text{ units} - 6 \text{ units} = 14 \text{ units}$$

$$14 \text{ units} \rightarrow \$325 + \$16 \times 2 = \$357 \quad \text{[M1]}$$

$$1 \text{ unit} \rightarrow \$25.50$$

$$20 \text{ units} \rightarrow \$510 \quad \text{[M1, A1]}$$

Kumar had \$510 at first.

(b) $15 \text{ units} \rightarrow \382.50

$$\$382.50 + \$80 = \$462.50 \quad \text{[M1, A1]}$$

Lily had \$462.50 in the end.

OR

$$33\frac{1}{3}\% \rightarrow \frac{1}{3}$$

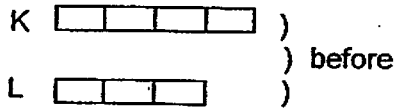

$$\$325 \div 4 = \$81.25 \rightarrow \blacksquare$$

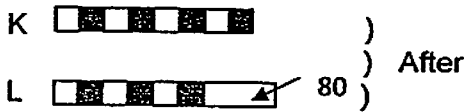

After K : L
 2 : 5
 4 : 10

After Lily has 3 parts + $\$81.25 \times 3$ + $\$80$
 7 parts $\rightarrow 81.25 \times 3 + 80$ (M1)
 $= 323.75$
 1 part $\rightarrow 46.25$

At first Kumar : 4 parts + 325 = 185 + 325 = 510 (M1 A1)

End Lily : 3 parts + 323.75 = 462.50 (M1 A1)

OR

$5 \times (4 \text{ units} - \$325) = 2 \times (3 \text{ units} + \$80)$
 $20 \text{ units} - \$1625 = 6 \text{ units} + \160
 $14 \text{ units} = \$1785$ (M1)
 1 unit = $\$127.50$

4 units = $\$510$ (M1 A1)

3 units = $\$382.50$
 $\$382.50 + \$80 = \$462.50$ (M1 A1)

OR

$4 \times (5 \text{ units} - \$80) = 3 \times (2 \text{ units} + \$325)$
 $20 \text{ units} - \$320 = 6 \text{ units} + \975
 $14 \text{ units} = \$1295$ (M1)
 1 unit = $\$92.50$

2 units + $\$325 = \$92.50 \times 2 + \$325 = \510 (M1 A1)

5 units = $\$462.50$ (M1 A1)

Handwritten notes:
 $20u - 1625 = 6u + 160$
 $14u = 1785$
 $1u = 127.5$
 $4u \rightarrow 510$
 $3u \rightarrow 382.50$