



RAFFLES GIRLS' PRIMARY SCHOOL

PRELIMINARY EXAMINATION  
2009

Name : \_\_\_\_\_ Index No: \_\_\_\_\_ Class: P 6 \_\_\_\_\_

28 August 2009

SCIENCE

Att: 1 h 45 min

|                             |       |       |
|-----------------------------|-------|-------|
| Your score out of 100 marks |       |       |
|                             | Class | Level |
| Highest score               |       |       |
| Average score               |       |       |
| Parent's signature          |       |       |

SECTION A (30 X 2 marks)

For each question from 1 to 30, four options are given. One of them is the correct answer. Make your choice (1, 2, 3 or 4). Shade the correct oval on the Optical Answer Sheet (OAS) provided.

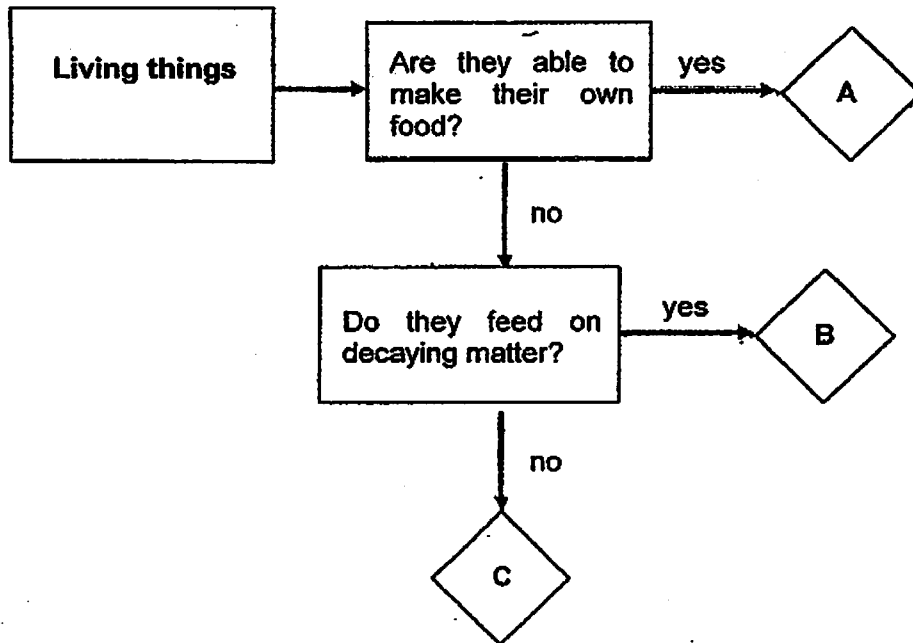

1 The flow chart below shows how some living things are classified.



Which one of the following identifies A, B and C correctly?

|     | A                | B           | C             |
|-----|------------------|-------------|---------------|
| (1) | mouse            | mushroom    | toad          |
| (2) | grass            | mould       | frog          |
| (3) | yeast            | toadstool   | staghorn fern |
| (4) | bird's nest fern | grasshopper | lizard        |

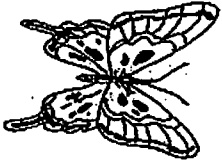
2 The table below shows the classification of some insects.

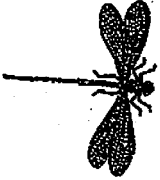
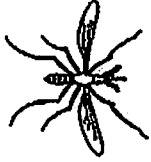
| Insects   |   |  |   |
|---|---|--|---|
| X   |   | Y  |   |
| has two pairs of wings  | does not have wings   | has two pairs of wings   | has a pair of wings   |
| A   | B   | C  | D   |
|  |  |  |  |
| butterfly   | ant   | dragonfly  | mosquito  |

Which one of the following sets of sub-headings best represents X and Y?

|     | X                      | Y                      |
|-----|------------------------|------------------------|
| (1) | has 3-stage life cycle | has 4-stage life cycle |
| (2) | lay eggs on land       | lay eggs in water      |
| (3) | has two body parts     | has three body parts   |
| (4) | cannot fly             | can fly                |

3

The diagrams below show the life cycles of animals X and Y.

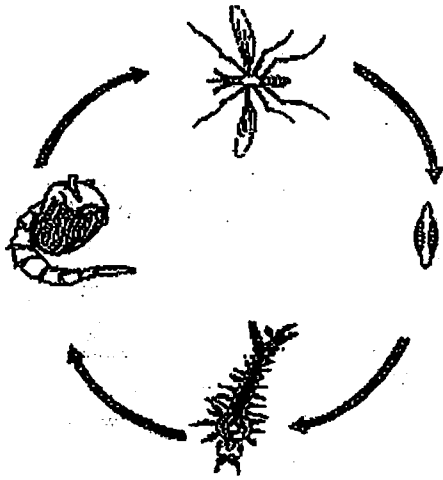

Animal X

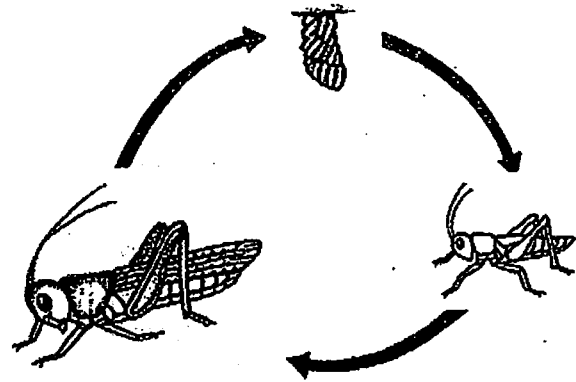

Animal Y

Based on the diagrams above, which of the following statements about animals X and Y is / are true?

- A Both the adults do not have wings.
- B Both the young do not live in water.
- C Both the adults do not give birth to their young alive.
- D Both are pests in at least one stage of their life cycles.

- (1) D only
- (2) A and B only
- (3) B and C only
- (4) C and D only

4

The diagram below shows a flow chart to differentiate some cells.

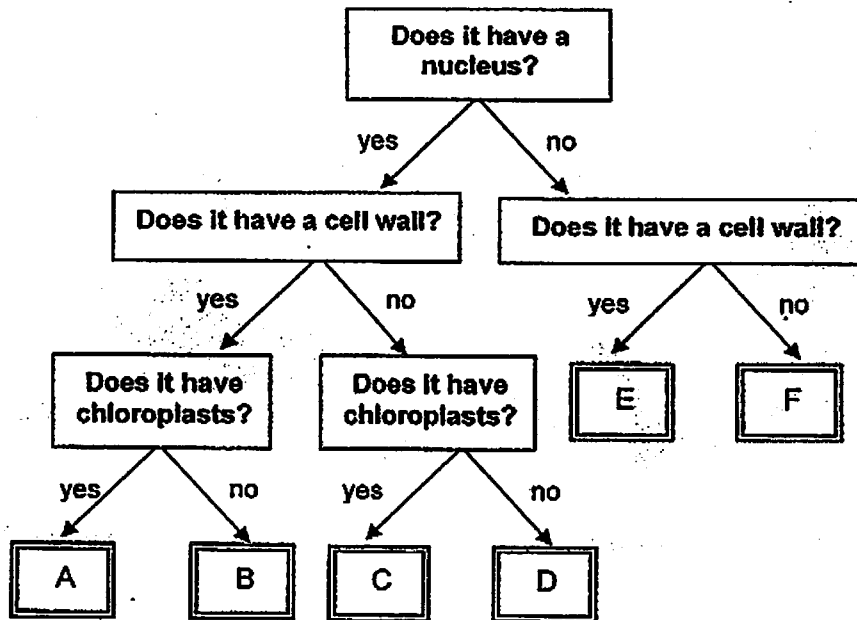

Based on the information above, four pupils made the following statements:

- Alica : Cells D and F can be animal cells.
- Bernice : Cells A, B and E can be plant cells.
- Christel : Cells A and C are able to photosynthesise.
- Daisy : Cells E and F are not cells as they do not have a nucleus.

Which of these pupils made (an) incorrect statement(s)?

- (1) Daisy only
- (2) Alica and Bernice only
- (3) Alica and Daisy only
- (4) Bernice and Christel only

- 5 The arrows in each of the following diagrams show the transfer of pollen grains between 4 pairs of flowers, A, B, C and D.

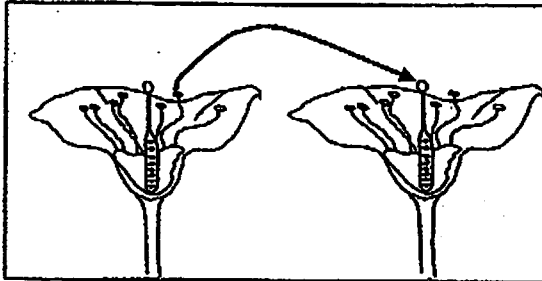

pair A

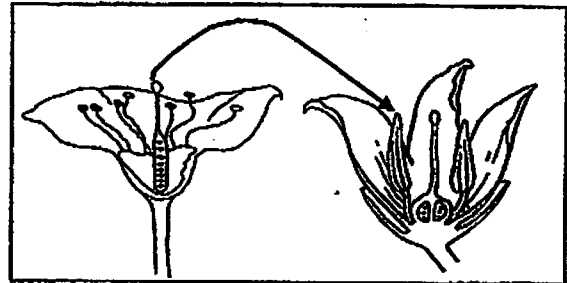

pair B

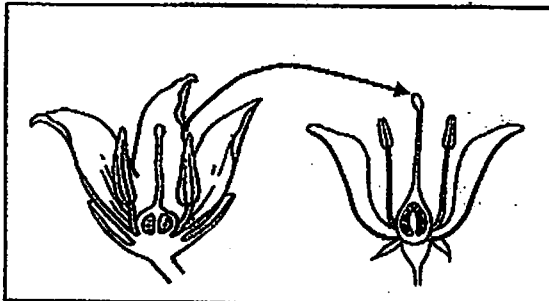

pair C

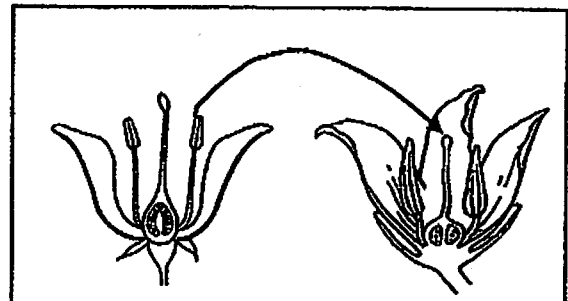

pair D

Key

→ direction in which pollen grains are transferred

Which pair(s) of flowers would most likely develop into fruit(s)?

- (1) A only
- (2) B only
- (3) C and D only
- (4) A, C and D only

6

An experiment was set up using four onions, W, X, Y and Z.

At the start of the experiment, one or two different part(s) of the onions was / were removed.

The different parts of the onion are shown in the diagram below.

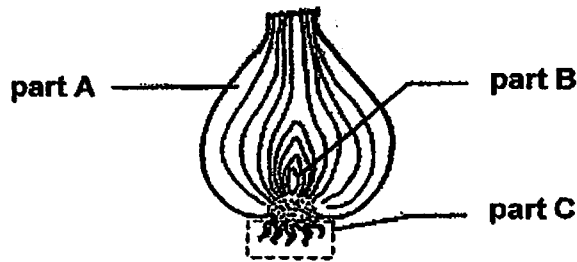

A cross-section of an onion

The table below shows the different part(s) of each onion, W, X, Y and Z, that was / were removed.

| onion | part A  | part B  | part C  |
|-------|---------|---------|---------|
| W     | removed | present | removed |
| X     | removed | present | present |
| Y     | present | removed | present |
| Z     | present | removed | removed |

Which one of these onions, W, X, Y or Z, would most likely grow a shoot first?

- (1) W
- (2) X
- (3) Y
- (4) Z

7 Sarah placed an equal number of similar seeds in containers P and Q.

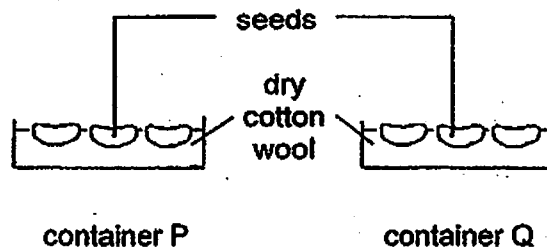

After one week, Sarah observed that only the seeds in container Q had germinated.

Based on Sarah's observations, which one of the following pairs describes correctly the conditions in which the seeds were exposed to in each container?

|     | container P   | container Q   |
|-----|---|---|
| (1) | <ul style="list-style-type: none"> <li>• placed under the sun</li> <li>• no water given</li> </ul>            | <ul style="list-style-type: none"> <li>• placed in a dark cupboard</li> <li>• no water given</li> </ul> |
| (2) | <ul style="list-style-type: none"> <li>• placed in a dark room</li> <li>• watered daily</li> </ul>            | <ul style="list-style-type: none"> <li>• placed under the sun</li> <li>• watered daily</li> </ul>       |
| (3) | <ul style="list-style-type: none"> <li>• placed in the freezer</li> <li>• watered daily</li> </ul>            | <ul style="list-style-type: none"> <li>• placed in a dark room</li> <li>• watered daily</li> </ul>      |
| (4) | <ul style="list-style-type: none"> <li>• placed in an air-tight container</li> <li>• watered daily</li> </ul> | <ul style="list-style-type: none"> <li>• placed under the sun</li> <li>• no water given</li> </ul>      |

8 Gaseous exchange takes place in the leaves of plants.

The table below shows the gases, A, B, C and D, involved during the 2 processes carried out by the leaves of plants.

| process        | gas taken in by the leaves | gas given out by the leaves |
|----------------|----------------------------|-----------------------------|
| respiration    | A                          | B                           |
| photosynthesis | C                          | D                           |

What are A, B, C and D likely to be?

|     | A              | B              | C              | D              |
|-----|----------------|----------------|----------------|----------------|
| (1) | water vapour   | oxygen         | carbon dioxide | hydrogen       |
| (2) | carbon dioxide | oxygen         | oxygen         | water vapour   |
| (3) | oxygen         | carbon dioxide | hydrogen       | carbon dioxide |
| (4) | oxygen         | carbon dioxide | carbon dioxide | oxygen         |

9 The diagram below shows parts of the human digestive system.

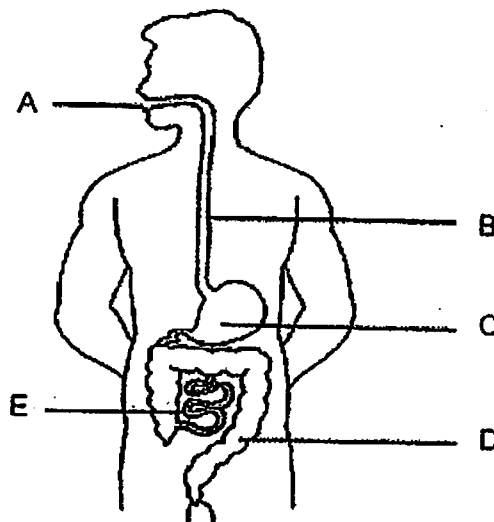

Which of these parts, A, B, C, D and E, produce digestive juices?

- (1) A, B and C only                      (2) A, C and E only  
 (2) B, D and E only                      (4) C, D and E only

- 10 Tiara put a bell jar over a well-watered plant. She covered it with a layer of black plastic bag and placed it under the sun from 7 am to noon. The diagram below shows her experimental set-up.

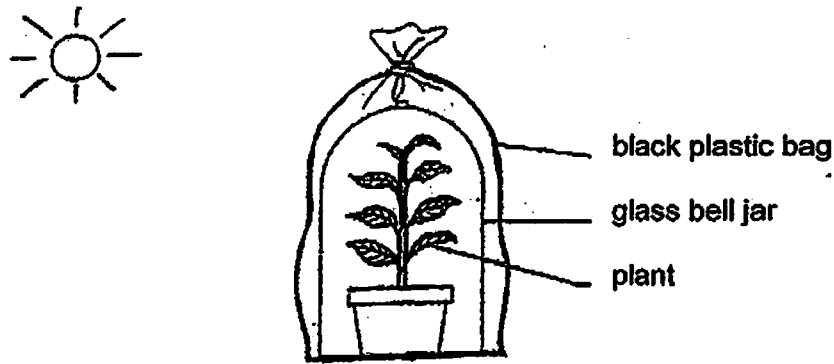

Which one of the following graphs shows correctly the changes in the levels of carbon dioxide and oxygen in the bell jar during this period of time?

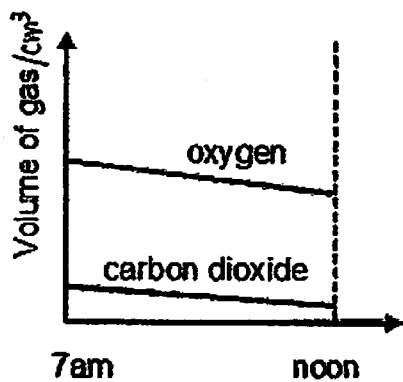

(1)

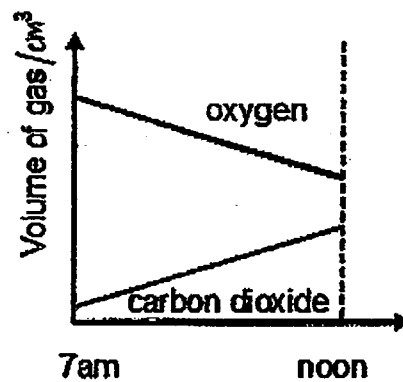

(2)

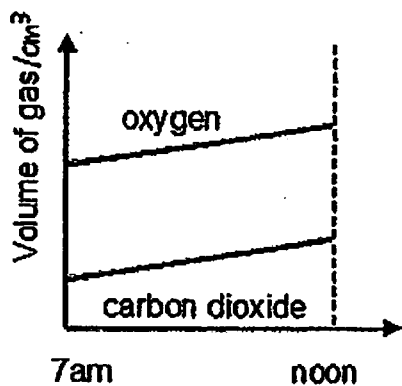

(3)

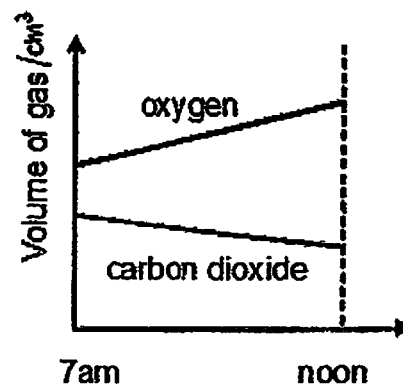

(4)

- 11 The diagram below shows the flow of blood from one part of the body to another.

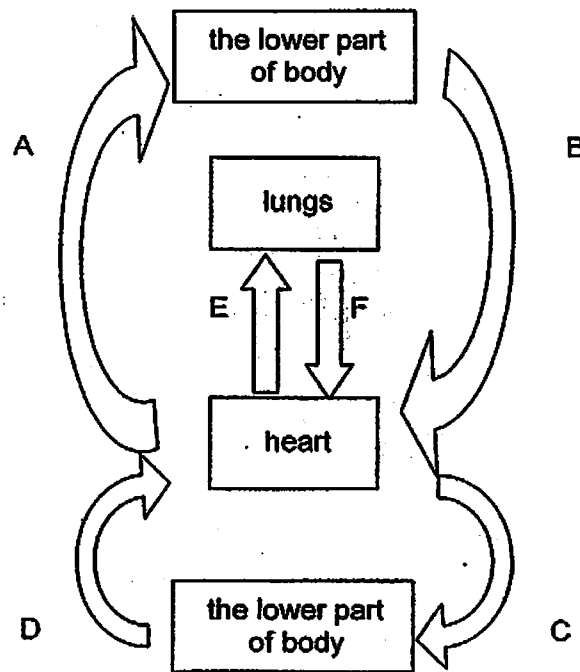

A, B, C, D, E and F represent the blood vessels in the body.

Which one of the following identifies correctly the type of blood found in these blood vessels?

|     | blood rich in oxygen | blood rich in carbon dioxide |
|-----|----------------------|------------------------------|
| (1) | A, C and E           | B, D and F                   |
| (2) | A and C              | B, D, E and F                |
| (3) | A, C and F           | B, D and E                   |
| (4) | A, D and E           | B, C and F                   |

- 12 To conduct an experiment, Susan prepared set-ups A and B using 2 similar plants as shown below.

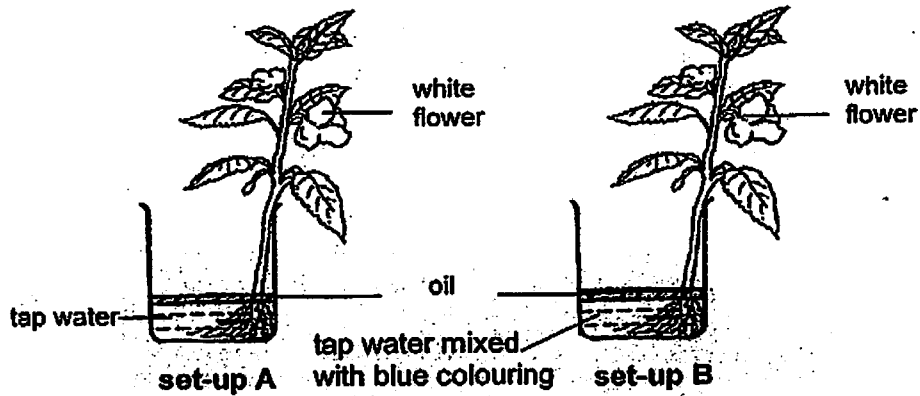

After a few days, she observed that the flowers and some parts of the leaves in set-up B had turned blue while the flowers in set-up A remained white.

Based on Susan's observations, what could she conclude from her experiment?

- (1) Water is transported throughout the plant by its xylem tubes.
- (2) Food is transported throughout the plant by its phloem tubes.
- (3) Water that is taken in by the roots is transported to other parts of the plant.
- (4) Food is produced in the leaves and transported to all parts of the plant.

- 13 One of the methods of controlling oil spill in the ocean is to surround the spillage with a barrier. The barrier prevents the oil from spreading to other parts of the ocean.

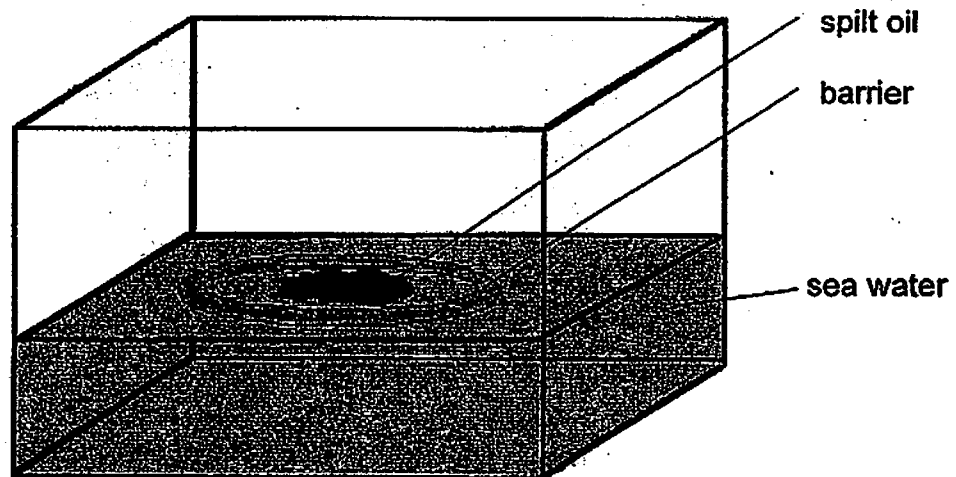

Professor Thamin conducted an experiment using 4 different blocks of the same volume, each made of a different material, A, B, C or D.

She took 4 identical beakers and filled each of them with an equal amount of sea water. Then she placed each block into each beaker, as shown in the diagrams below.

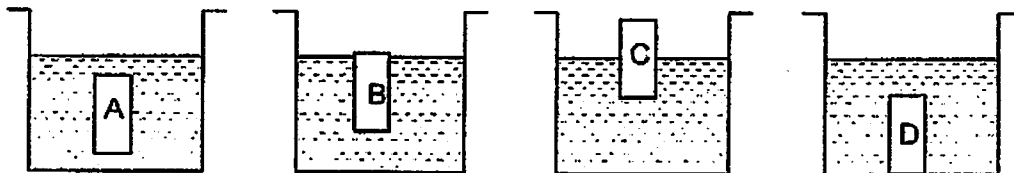

Which one of these materials, A, B, C or D, is the most suitable for making the barrier?

- (1) A
- (2) B
- (3) C
- (4) D



- 15 The diagram below shows parts of organism X found on a small island.

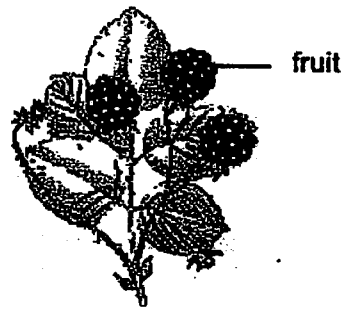

X is pollinated by organism Y.

One day, organism Z, which feeds on X, invaded the island.

How will the presence of Z affect X in the next few years?

- A There will be fewer fruits formed.
  - B The population size of X will not be affected.
  - C The population size of X will increase at a faster rate than before.
- (1) A only                      (2) C only  
 (3) A and B only              (4) A and C only

- 16 The diagram below shows a food web involving 8 organisms, A, B, C, D, E, F, G and H.

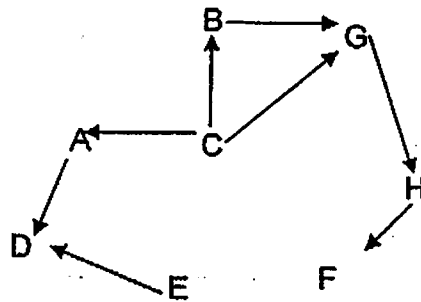

Based on the food web above, John constructed four different food chains.

Which one of the following food chains that John had formed was correct?

- (1) E → D
- (2) A → D ← E
- (3) C → G → B
- (4) B → G → H → F

- 17 The diagram below shows a pump fitted to a container which has a capacity of  $200 \text{ cm}^3$ .

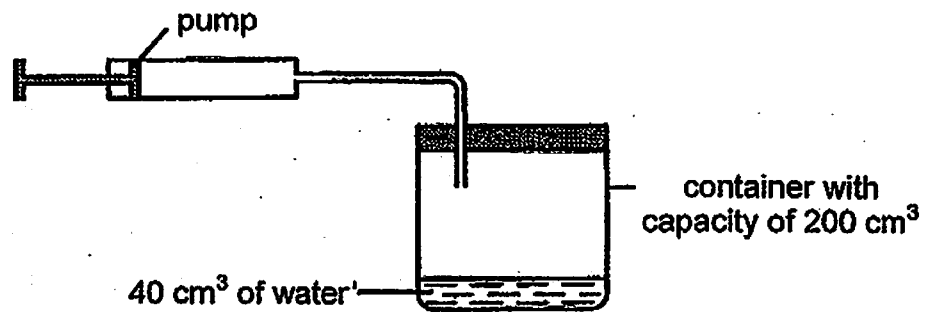

Each time the pump was pushed in completely,  $100 \text{ cm}^3$  of air would enter the container.

Based on the information above, which one of the following graphs represents correctly the changes in the volume of air inside the container after the pump was pushed in completely once?

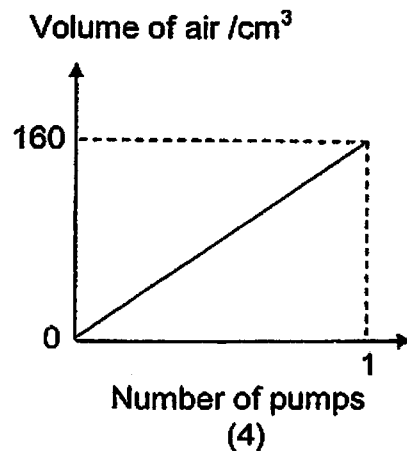
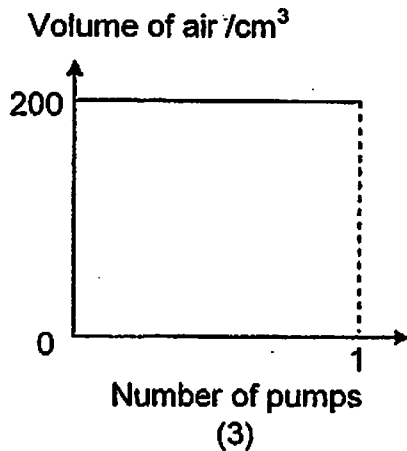
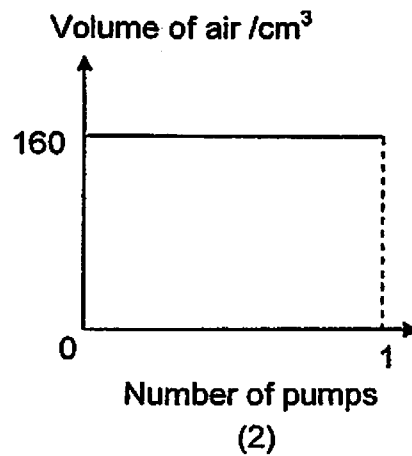
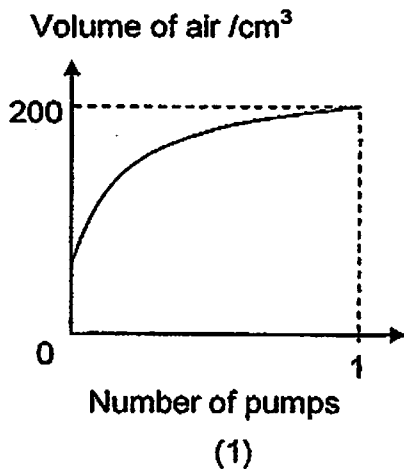

18 Chloe prepared the following set-up to collect fresh water from pond water.

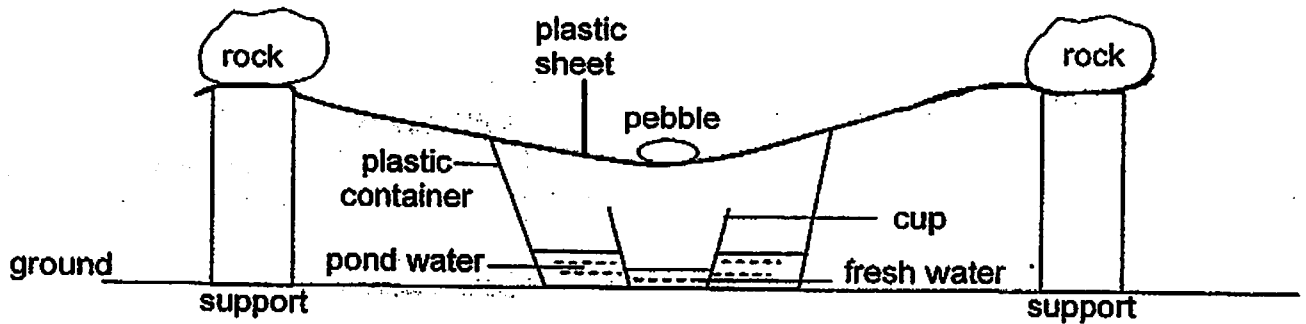

She placed the set-up in an open field on a sunny day. After a few hours, she managed to collect some fresh water in the cup.

Chloe felt that the amount of fresh water she had collected was too little.

Which one of the following changes should Chloe make to the set-up so that more fresh water could be collected in the cup?

She should use \_\_\_\_\_.

- (1) a smaller cup
- (2) a smaller pebble
- (3) a smaller plastic container
- (4) sea water instead of pond water

19 P, Q, R, S, T and U represent different locations on the Earth.

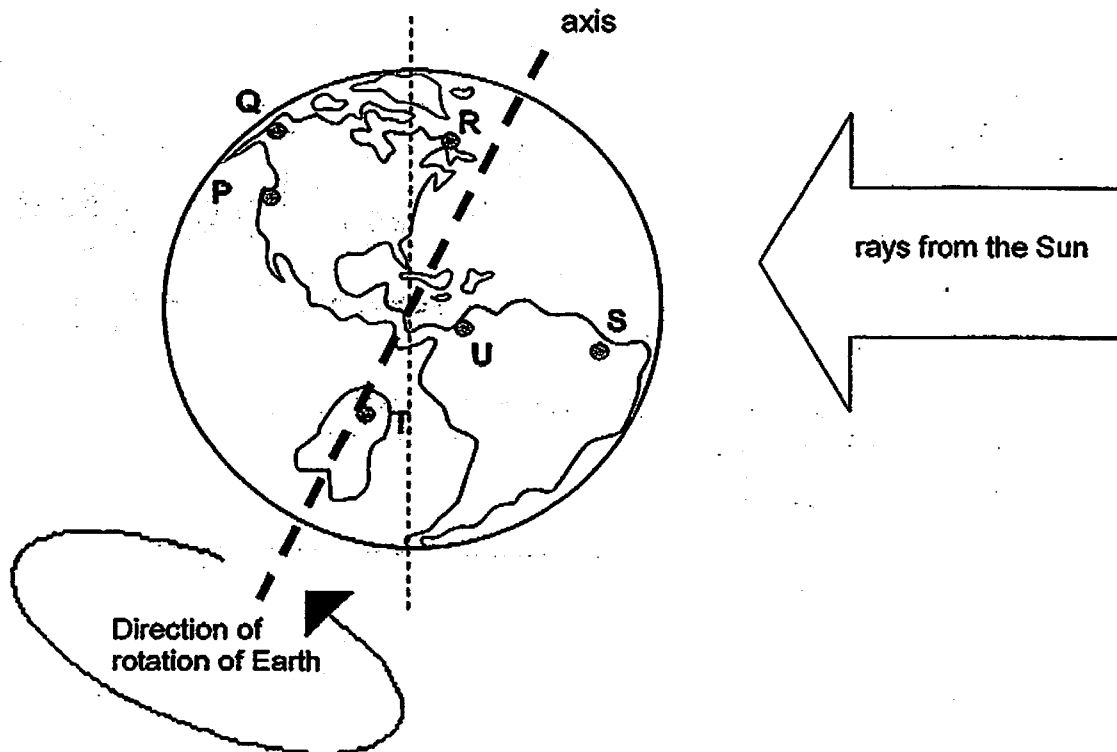

3 children located at different parts of the Earth made the following statements at the same time :

Abigail : I can see the stars in the night sky.

Beeling : The Sun is going to rise soon.

Catherine : It is going to be noon soon.

Based on the information above, which one of the following shows correctly where the children are on the Earth?

|     | Abigail | Beeling | Catherine |
|-----|---------|---------|-----------|
| (1) | P       | T       | U         |
| (2) | P       | R       | S         |
| (3) | Q       | T       | S         |
| (4) | Q       | R       | U         |

- 20 The diagram below shows how electrical energy is produced in a power station.

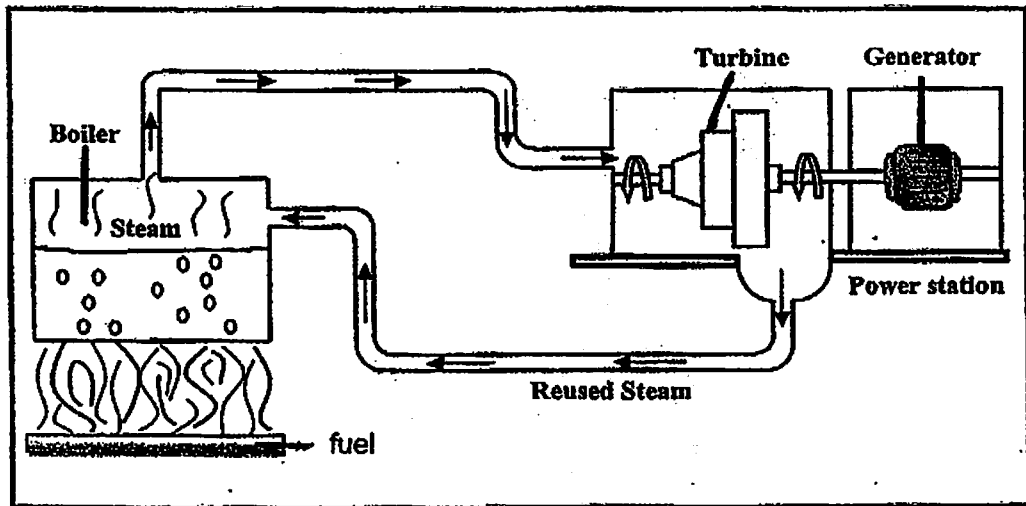

Which one of following shows correctly the energy conversions that take place in the production of electrical energy?

- (1) heat energy  $\longrightarrow$  kinetic energy  $\longrightarrow$  electrical energy
- (2) potential energy  $\longrightarrow$  heat energy  $\longrightarrow$  electrical energy
- (3) heat energy + light energy  $\longrightarrow$  kinetic energy  $\longrightarrow$  electrical energy
- (4) potential energy  $\longrightarrow$  heat energy  $\longrightarrow$  kinetic energy  $\longrightarrow$  electrical energy

- 21 The diagram below shows the use of shadows in 'Wayang Kulit', a puppetry art.

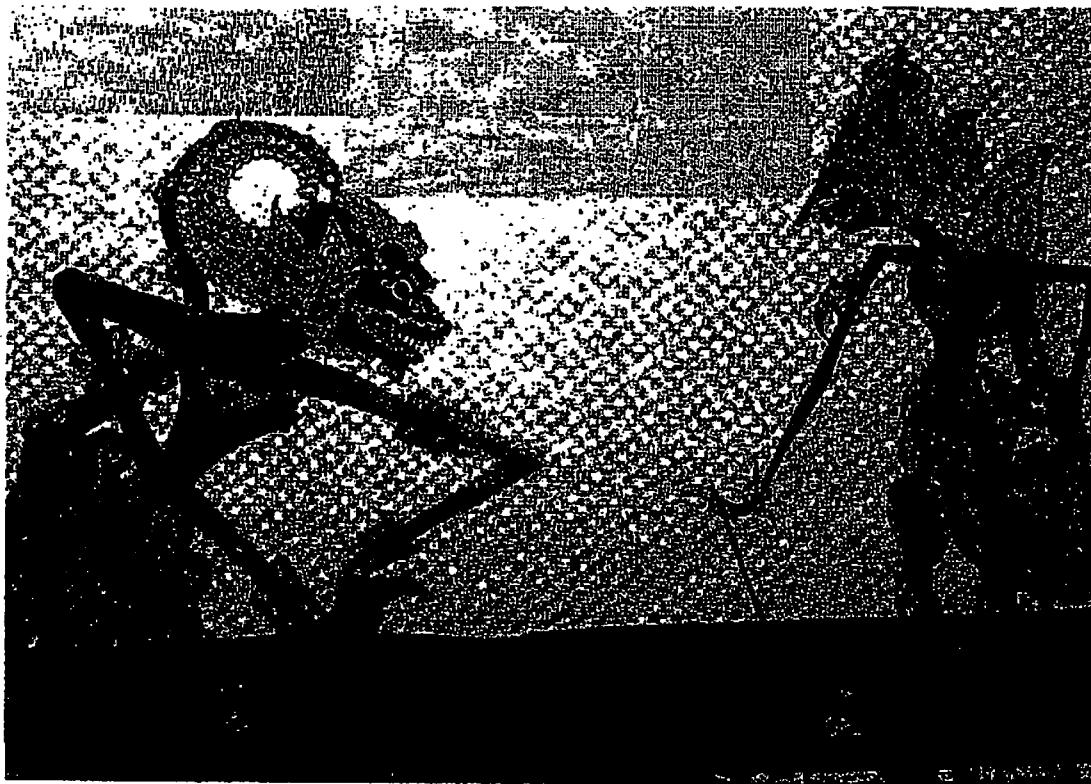

Which of the following statement(s) explain(s) how the shadows are formed clearly on the screen?

- A A transparent cloth is used as a screen.
  - B The puppets are made of opaque materials.
  - C A light source is placed before the screen while the puppets are behind the screen.
- (1) B only
- (2) A and B only
- (3) B and C only
- (4) A, B and C

- 22 Peter had two identical beakers, X and Y, each filled with an equal amount of water. He heated the water in the beakers for 20 minutes until the water boiled.

The graph below shows the changes in the temperature of the water in both beakers for the first 9 minutes.

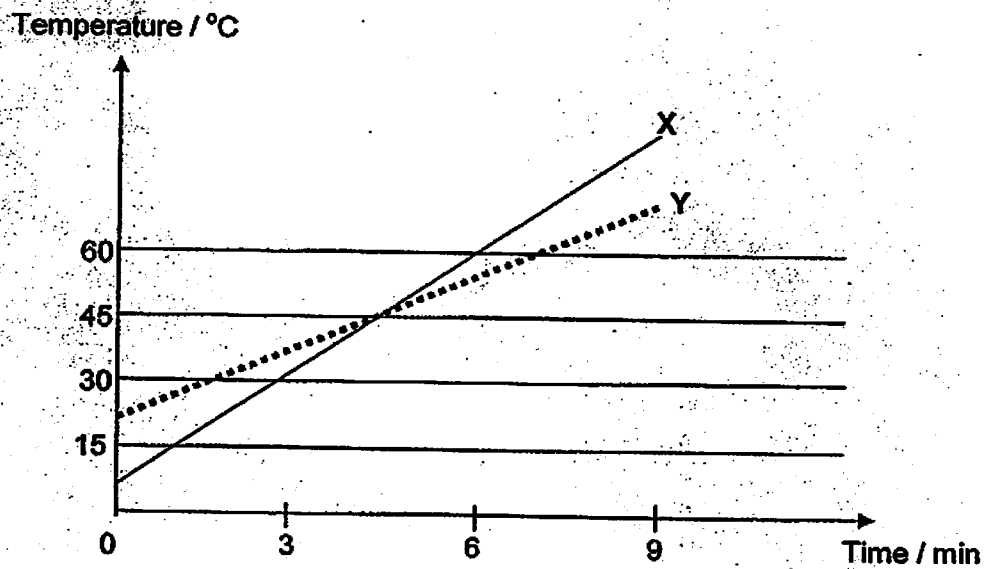

Which of the following statements is / are true?

- A The water in beaker X was heated with a stronger flame.
  - B Both beakers of water would reach the same temperature at the end of 20 minutes.
  - C Both beakers had water at room temperature at the start of the experiment.
- (1) A only  
(2) B only  
(3) A and B only  
(4) B and C only

- 23 James set up four circuits, S, T, U and V, using identical batteries and bulbs as shown in the diagrams below.

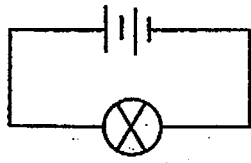

**circuit S**

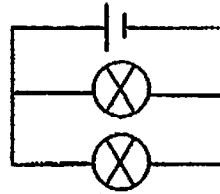

**circuit T**

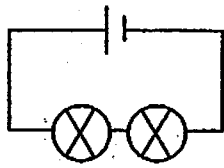

**circuit U**

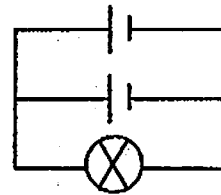

**circuit V**

In which one of the following circuits, S, T, U or V, will the bulb(s) remain lit for the longest period of time?

- |               |               |
|---------------|---------------|
| (1) Circuit S | (2) Circuit T |
| (3) Circuit U | (4) Circuit V |



- 25 The diagram below shows a circuit with three gaps, E, F and G, where different objects could be connected to.

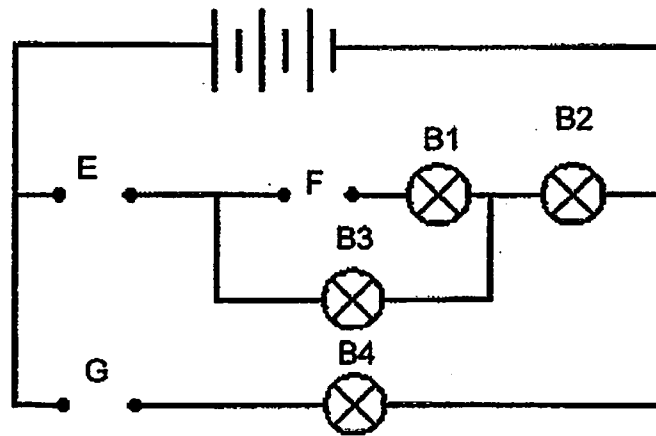

Wei Lin had three rods, X, Y and Z. She connected the ends of each rod to each of the gaps at E, F and G respectively. She recorded her observations in the table below. A tick (✓) in the box indicates that the bulb lit up.

| position of rod |   |   | bulb(s) that lit up |    |    |    |
|-----------------|---|---|---------------------|----|----|----|
| E               | F | G | B1                  | B2 | B3 | B4 |
| X               | Y | Z |                     | ✓  | ✓  | ✓  |

Which one of the following shows the correct observations made of the bulbs for rods X, Y and Z placed at the various positions?

|     | position of rod |   |   | bulb(s) that lit up |    |    |    |
|-----|-----------------|---|---|---------------------|----|----|----|
|     | E               | F | G | B1                  | B2 | B3 | B4 |
| (1) | X               | Z | Y |                     | ✓  | ✓  | ✓  |
| (2) | Y               | Z | X |                     |    | ✓  | ✓  |
| (3) | Z               | Y | X | ✓                   | ✓  | ✓  |    |
| (4) | Y               | X | Z |                     |    |    | ✓  |

- 26 The set-up below consists of three rings A, B and C. Two of them are ring magnets and one is a plastic ring. Ring B "floats" above ring C.

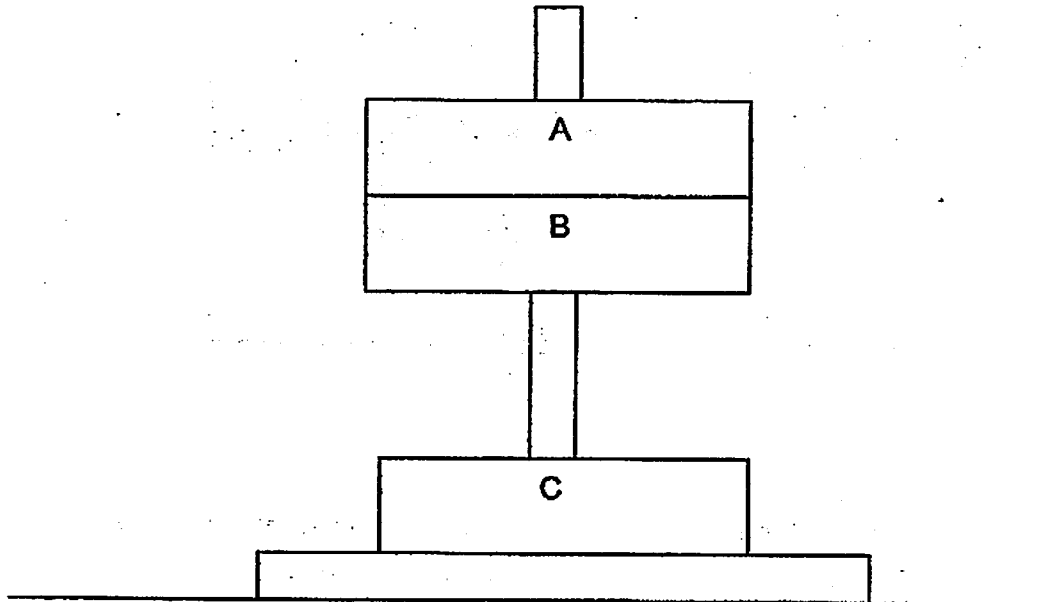

Based on the information above, which of the following statements is/ are most likely to be true?

- A Ring A is a magnet.
  - B Ring B is the plastic ring.
  - C Unlike poles of rings A and B are facing each other.
  - D Like poles of rings B and C are facing each other.
- 
- (1) C only
  - (2) D only
  - (3) A and B only
  - (4) A and C only

27 Which one of the diagrams below would require the greatest effort to move the 5 kg box from point X to Y?

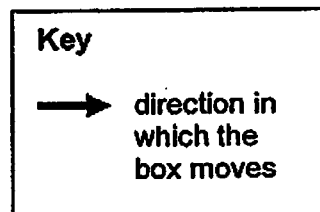
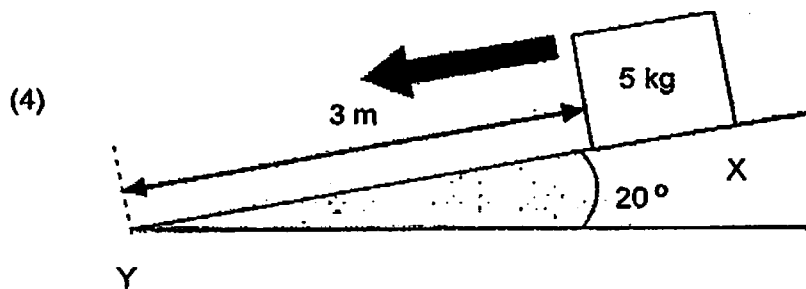
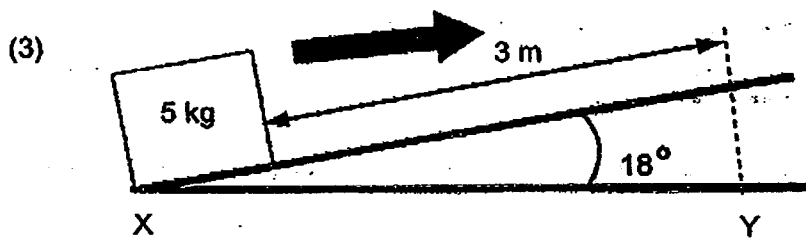
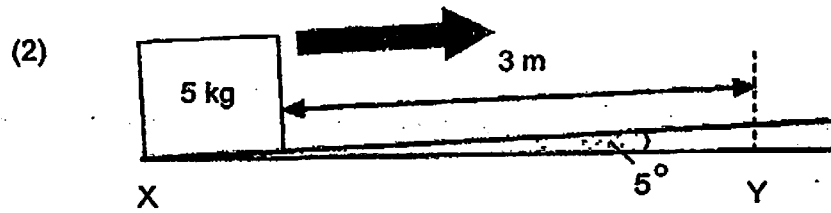
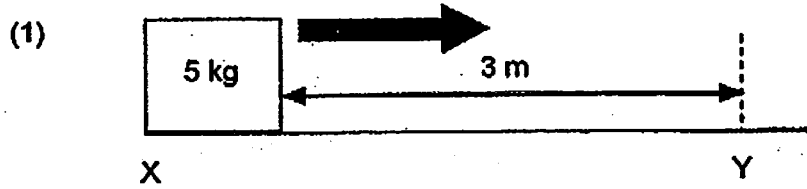

- 28 Sam pushed loads of the same mass up to the same height using two ramps, Q and R, which had the same angle of inclination,  $X^\circ$ . He noticed that he required more effort to push the load up ramp R than Q.

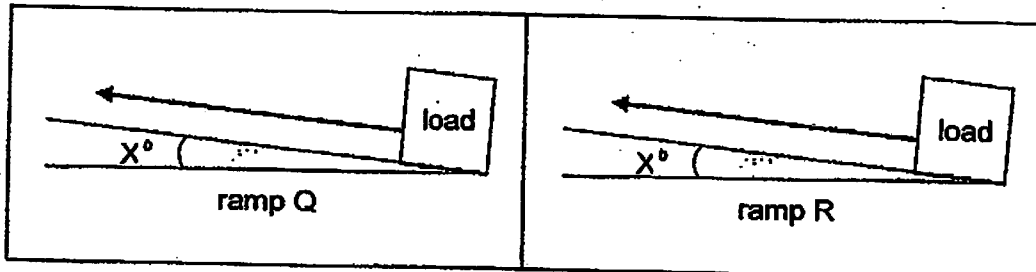

What possible conclusions could Sam make about the two ramps, Q and R?

- A The surface of ramp R was rougher than ramp Q.
  - B There was less friction between the load and the surface of ramp Q than the surface of ramp R.
  - C The distance moved by the effort up ramp Q was greater than the distance moved by the effort up ramp R.
  - D The distance moved by the load up ramp R was greater than the distance moved by the load up ramp Q.
- (1) C only
- (2) A and B only
- (3) A and C only
- (4) B and D only

- 29 Four identical balls, W, X, Y and Z, were hung from a pole using strings of different lengths as shown in the diagram below.

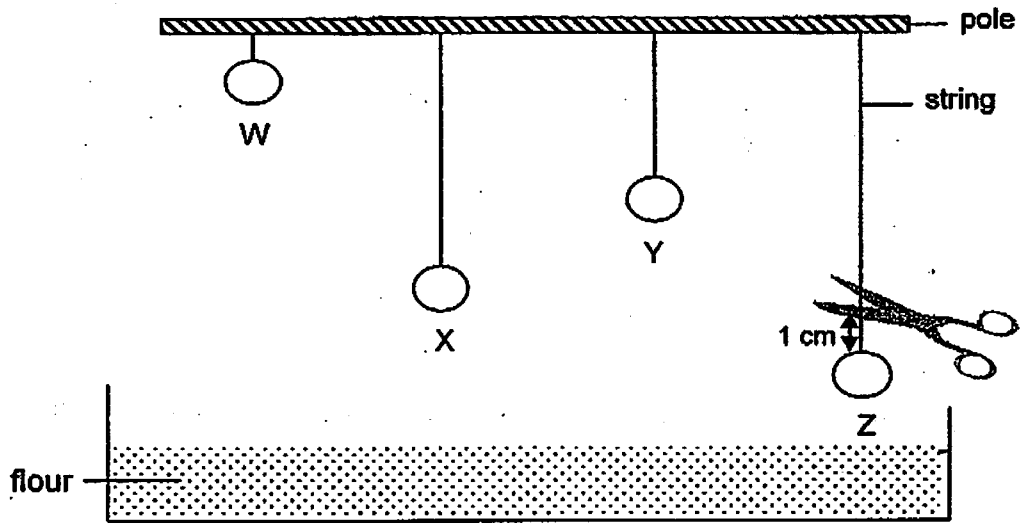

Each string was cut 1 cm above each ball. The balls landed in a container of flour placed directly below. Four dents of different depths were created in the flour by the four balls.

Which one of the following diagrams shows correctly the four dents in the flour made by the four balls respectively?

- (1)
- (2)
- (3)
- (4)

- 30 The diagram below shows two identical iron balls, A and B, moving towards each other at the same speed.

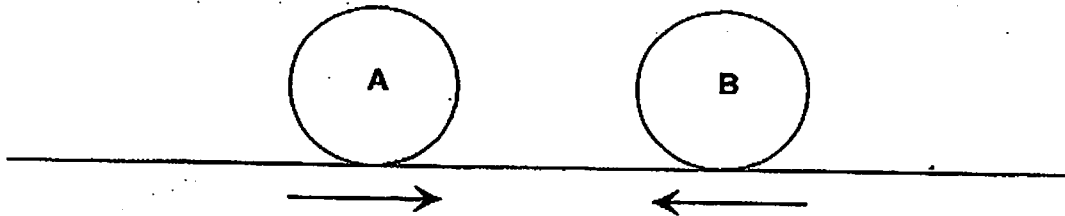

Which one of the following describes correctly what will happen when the two balls collide?

- (1) Balls A and B will move back in opposite directions at the same speed.
- (2) Balls A and B will move back in opposite directions at different speeds.
- (3) Ball A will move back in the opposite direction while Ball B will stop moving upon hitting Ball A.
- (4) Ball A will stop moving upon hitting Ball B while Ball B will move back in the opposite direction.

Name: \_\_\_\_\_ Index No: \_\_\_\_\_ Class: P6 \_\_\_\_\_

**SECTION B (40 marks)**

For questions 31 to 46, write your answers clearly in the spaces provided.

The number of marks available is shown in brackets [ ] at the end of each question or part question.

31 The diagram below shows Tim and Kate's family tree for the inherited characteristic of eye colour.

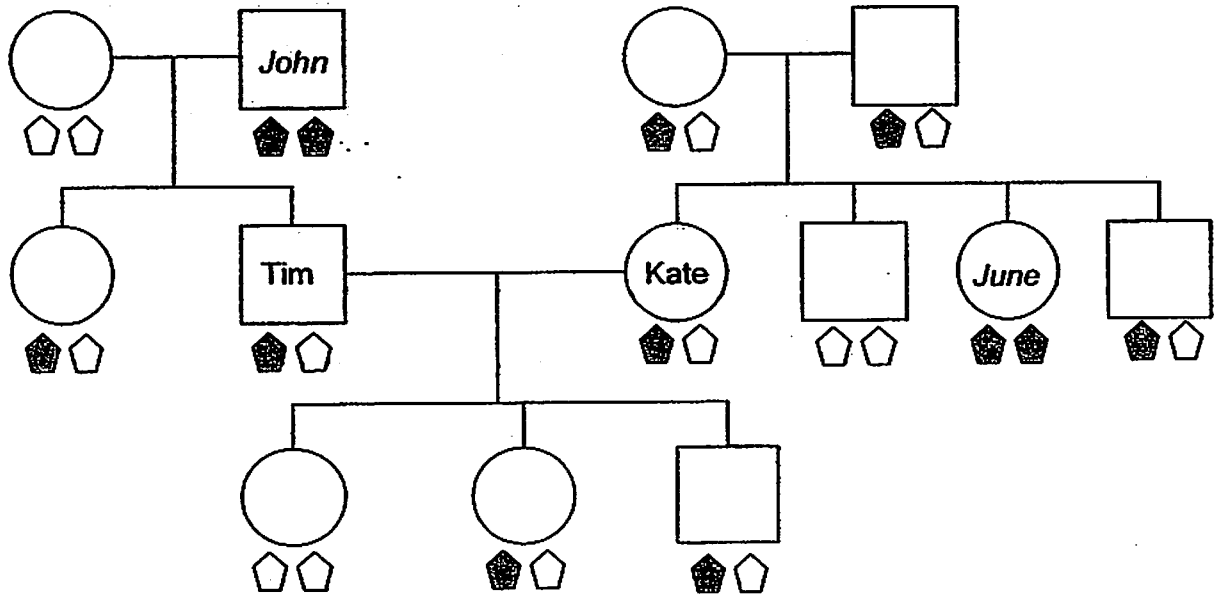

**Key:**

|   |        |                 |
|---|--------|-----------------|
| = female                                | = male | = blue eyes     |
| = genetic information for non-blue eyes |        | = non-blue eyes |
| = genetic information for blue eyes     |        | = non-blue eyes |

- The genetic information for blue eyes remains hidden if it is paired with that for non-blue eyes.
- Only John and June have blue eyes because they have inherited both pieces of genetic information for blue eyes from each of his/her own parents.

Based on the information on page 29, answer the following questions:

- (a) How many of Kate's siblings have blue eyes? [1]

---

- (b) Tim and Kate's son got married and his wife gave birth to a daughter with blue eyes.

Complete the family tree on page 29 by **DRAWING** the following: [2]

- (i) the two new members in the family **AND**  
(ii) the genetic information for each of the two new family members

32 Hillary used the following set-up to conduct an experiment.

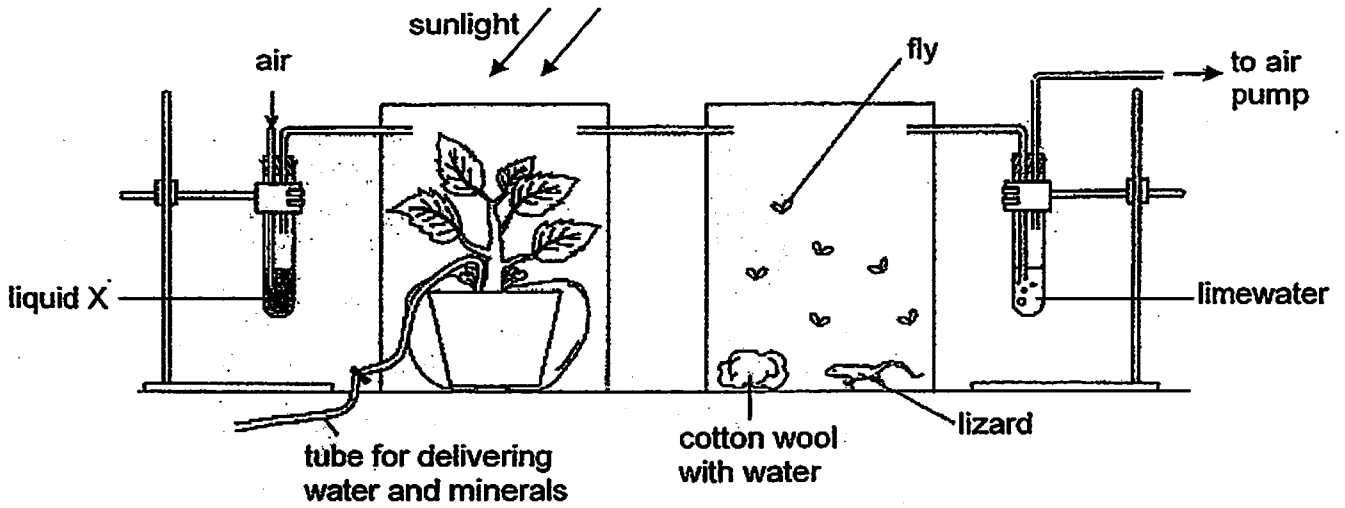

Based on the diagram above, answer the following questions:

- (a) To show that the lizard was dependent on the plant for its survival, Hillary placed liquid X to remove a substance from the air.

State the function of liquid X in Hillary's set-up.

[1]

---

---

- (b) Explain how the lizard was dependent on the plant for its survival. [1]

---

---

- (c) After some time, what would Hillary observe about the limewater?  
Give a reason for your answer.

[1]

---

---

- 33 Trixie conducted an experiment using identical beakers to find out if the number of leaves on a plant affects the amount of water that it loses to its surrounding.

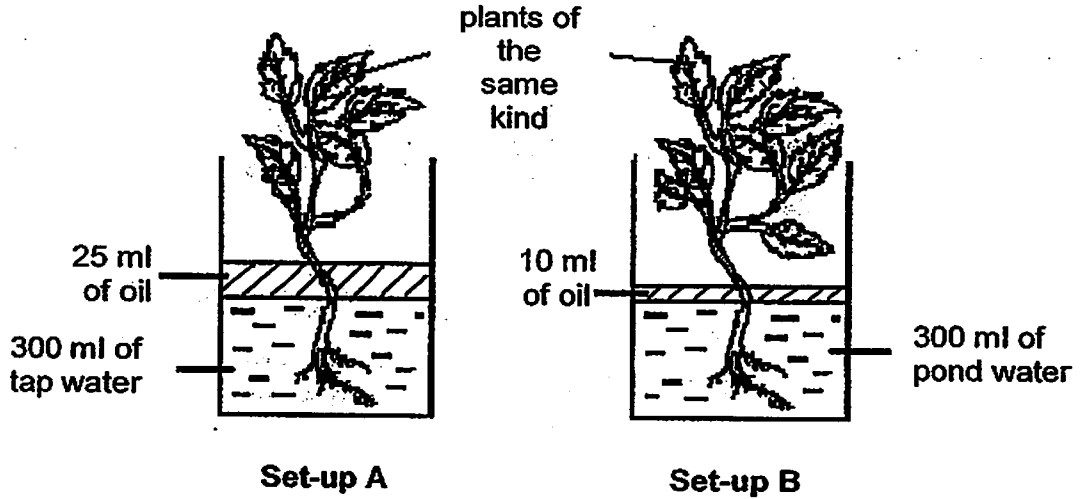

- (a) From the information provided above, suggest 2 ways to ensure that a fair test was conducted for the experiment. [2]

(i) \_\_\_\_\_

(ii) \_\_\_\_\_

- (b) If Trixie had conducted a fair test as you suggested in (a), Set-up A would act as a control set-up for the experiment.

Suggest why set-up A was required for her experiment. [1]

\_\_\_\_\_  
 \_\_\_\_\_

- 34 Mangrove trees are found in muddy swamps. They have special roots and other structural adaptations that enable them to survive in the swamp which most species of plants are unable to do so.

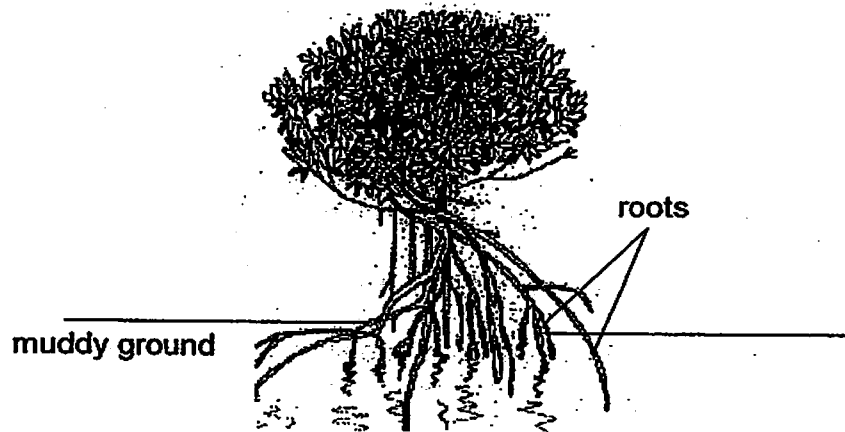

- (a) Other than having plenty of water, suggest **ANOTHER** advantage that the mangrove trees have for growing in the swamp compared to other species of plants. [1]

---

---

- (b) The mangroves trees have roots as shown in the diagram above. These roots are unable to take in oxygen or release carbon dioxide. Suggest why such roots are necessary for such trees to survive in the muddy ground. [1]

---

---

- 35 The food chain below shows the food relationships among the planktons, sponges and nudibranchs.

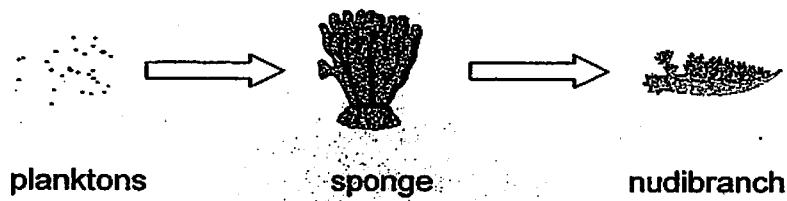

Sponges are found in water that is slightly further away from the seashore. Only a few types of organisms feed on them as they are normally poisonous.

Nudibranchs are slug-like creatures, without shells, that feed on sponges.

A sponge crab will cut out pieces of the sponge and attach them on itself. The pieces of sponges on the crab survive well.

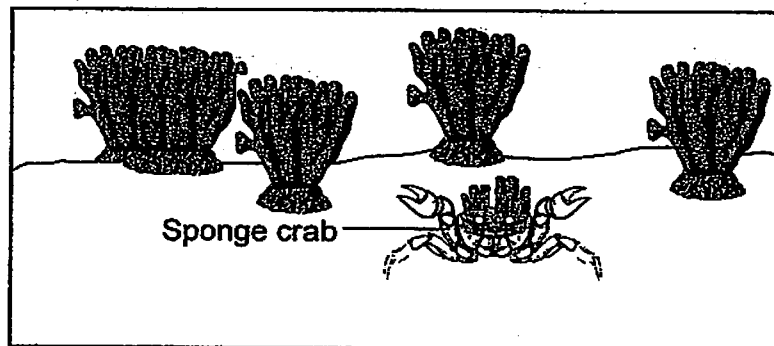

Based on the information provided, answer the following questions:

- (a) Suggest why the sponge crab attaches pieces of sponge to itself. [1]

---

---

- (b) Suggest how the pieces of sponge that are attached on the crab benefit from the relationship. [1]

---

---

36 Kerri wanted to compare the hardness of four different materials, A, B, C and D. She scratched them, one at a time, with rods each made from a different material; plastics, wood or metal.

She recorded her observations in the table below.

A tick (  $\checkmark$  ) indicates the presence of a scratch mark made by each rod on the material.

| material | presence of scratch marks made by |              |              |
|----------|-----------------------------------|--------------|--------------|
|          | plastic rod                       | wooden rod   | metal rod    |
| A        |                                   |              | $\checkmark$ |
| B        | $\checkmark$                      | $\checkmark$ | $\checkmark$ |
| C        |                                   |              |              |
| D        |                                   | $\checkmark$ | $\checkmark$ |

Based on the information above, answer the following questions:

- (a) Arrange the materials, A, B, C and D, in order according to their hardness. Write letters A, B and D only in the boxes provided below. The letter C has been written for you. [1]

hardest

The diagram below shows a crane that is used to lift heavy objects.

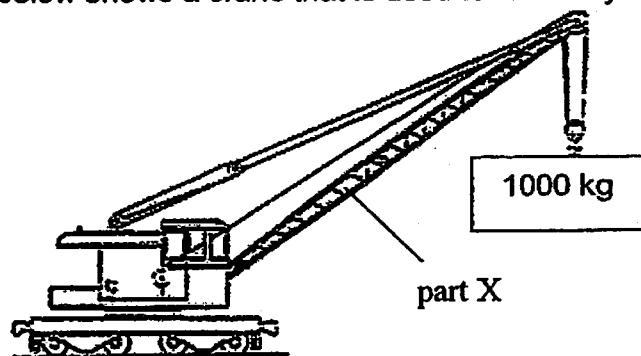

- (b) Even though material C is the hardest material, explain why it may NOT be the most suitable material to make part X of the crane. [2]

---



---



---

37 Aastha had a glass container with a heater installed in it. She filled the container with some green gas as shown in **Diagram 1** below.

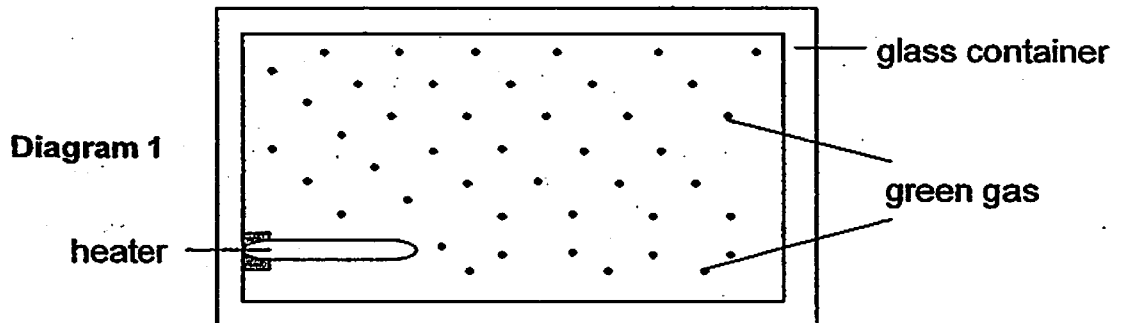

She switched on the heater and after some time, she saw the green gas moving in the directions as shown in **Diagram 2** below.

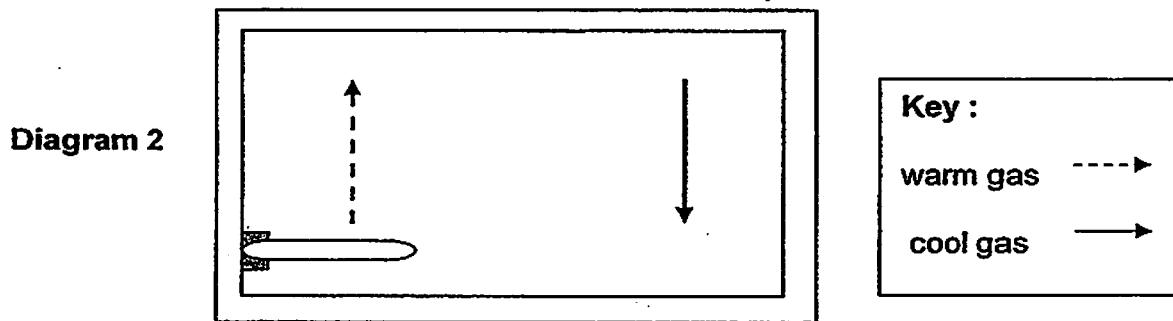

(a) Based on the information above, what could Aastha infer about air?

[1]

---



---

The diagram below shows the layout of Aastha's dining room.

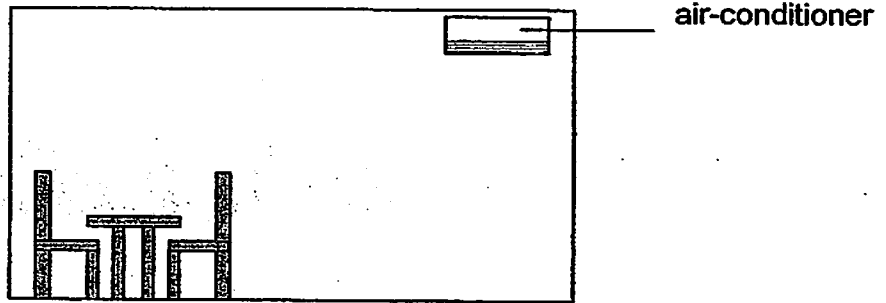

- (b) Based on part (a) on page 36, give a reason why an air-conditioner is usually placed near the ceiling and not near the floor. [1]

---

---

---

---

- 38 The diagram below shows the various positions of a metal ball when released from point A.

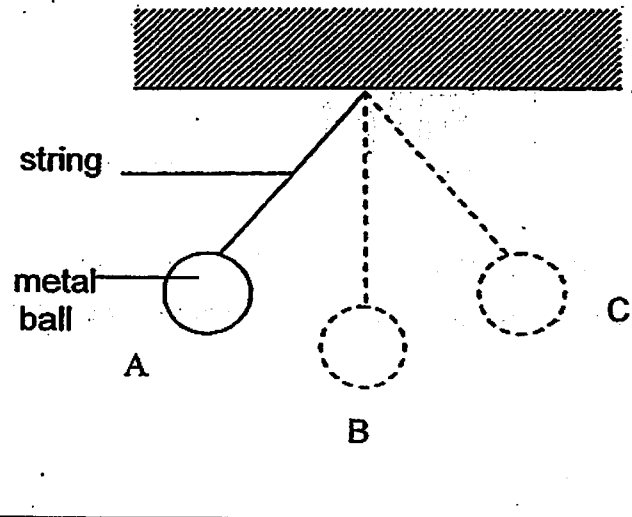

- (a) State the energy changes of the metal ball from points A to C through B. [1]

---

---

- (b) Based on the diagram on page 38, which one of the following graphs best represents the change in potential energy of the metal ball?

**LABEL** the correct graph with a letter, P, in the appropriate box given below. [1]

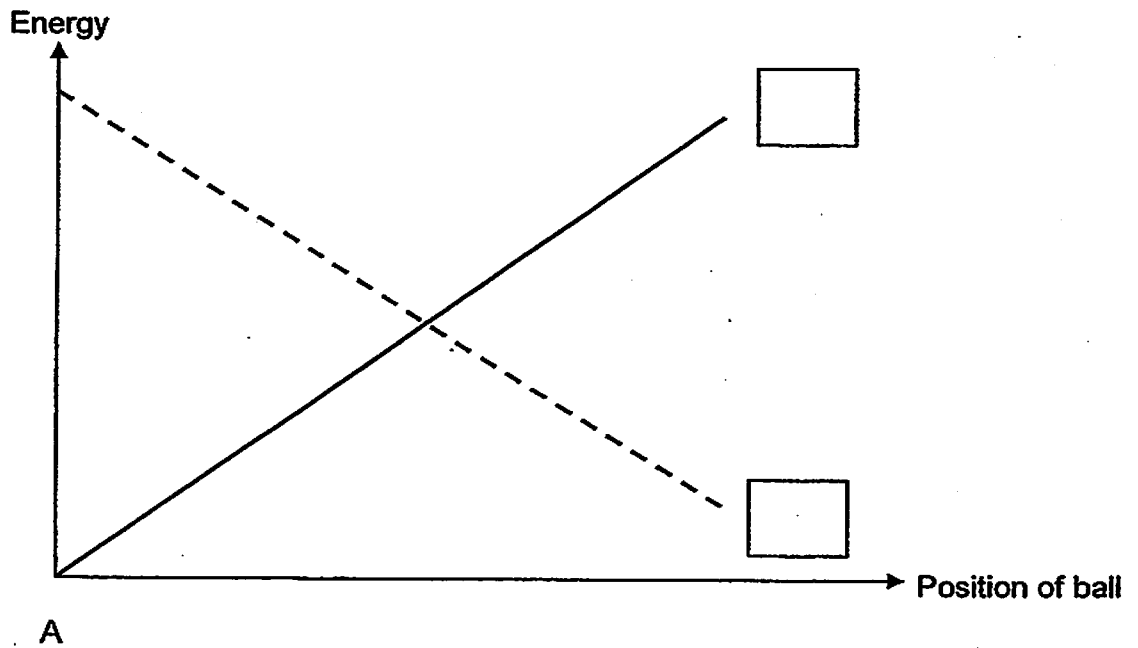

- (c) Explain your choice of the graph in (b) above. [1]

---

---

---

- 39 Huiming arranged 3 objects, A, B and C, in a straight line as shown in the following set-up.

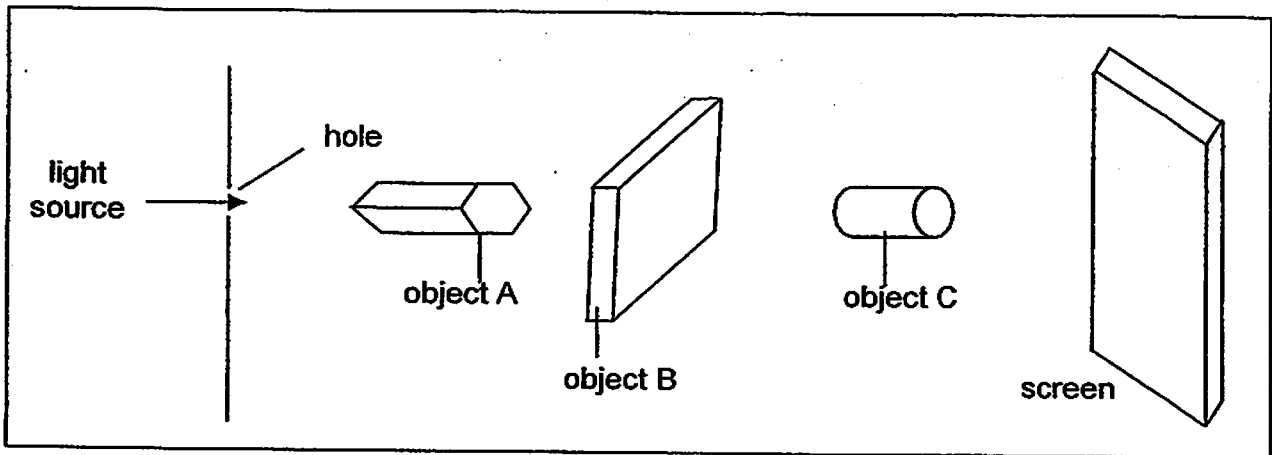

Huiming shone light at objects A, B and C. She saw a shadow cast on the screen as shown below.

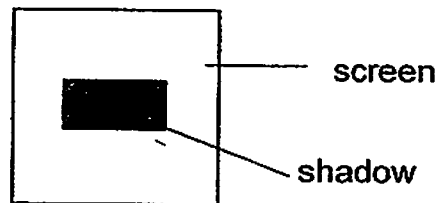

- (a) Based on the information above, put a tick (✓) in the correct box for each of the following statements: [11/2]

| Statement                      | true | false | not possible to tell |
|--------------------------------|------|-------|----------------------|
| (i) Object A is transparent.   |      |       |                      |
| (ii) Object B is opaque.       |      |       |                      |
| (iii) Object C is translucent. |      |       |                      |

The diagram below shows the positions of the mirrors, A, B, C, and D, placed near / at the bend of a 2-way road.

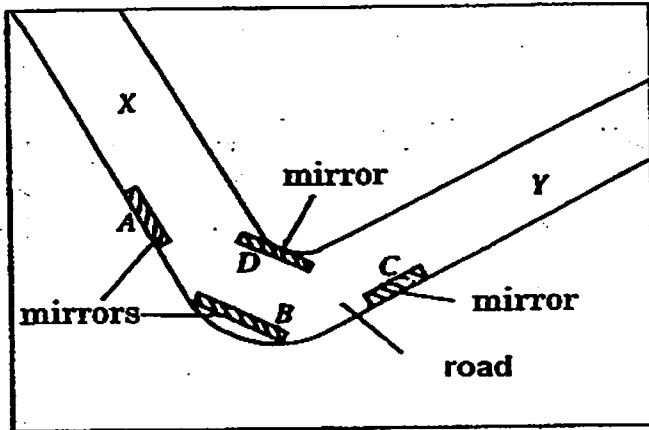

- (b) Which one of these mirrors will enable motorists coming from X and Y to see each other before they meet at the sharp bend?

[1]

- (c) In the diagram above, DRAW arrows (→) to indicate how the reflection of light allows the motorist at X to see the motorist at Y before they meet.

[1]

- 40 Two bars, P and Q, of the same diameter, were wrapped tightly with paper of the same size and thickness as shown below.

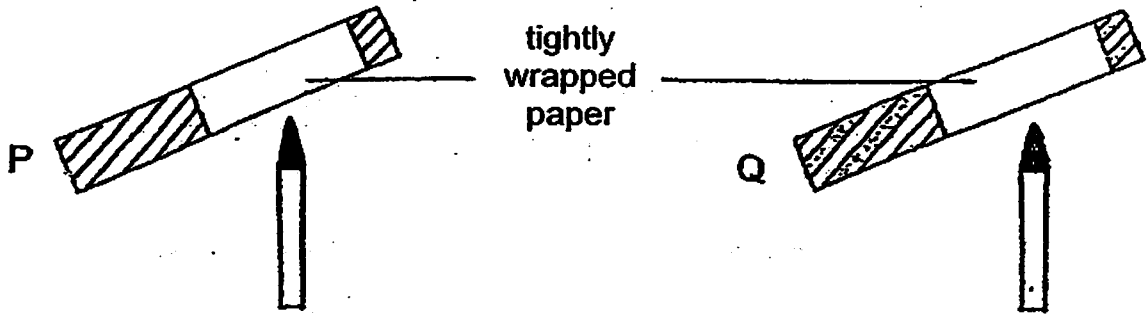

Each bar was heated over a flame for the same duration. After some time, the paper on bar P was burnt but NOT the paper on bar Q.

- (a) Which of the two materials below are most likely to be P and Q? [1]

Iron \_\_\_\_\_

Wood \_\_\_\_\_

- (b) Explain your answers in part (a) above. [1]

---

---

---

---



42 Ruiyi set up circuit W as shown in the diagram below.

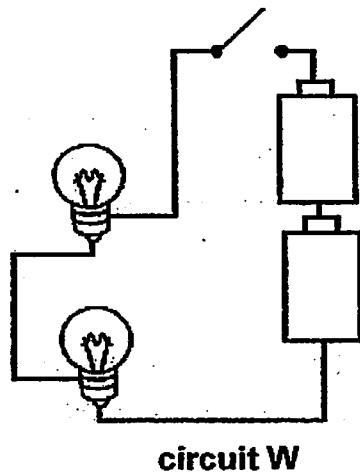

Her friend, Esther, told her that she had a two-way switch that could improve Ruiyi's set-up such that when one bulb fused, the other bulb could remain lit.

Esther connected the two-way switch to form part of circuit Y as shown in the diagram below. The two-way switch was made up of three metal contacts, A, B, and C, fixed on a small piece of wood. A steel paper clip was fixed at A such that it was able to touch either B or C to close the circuit.

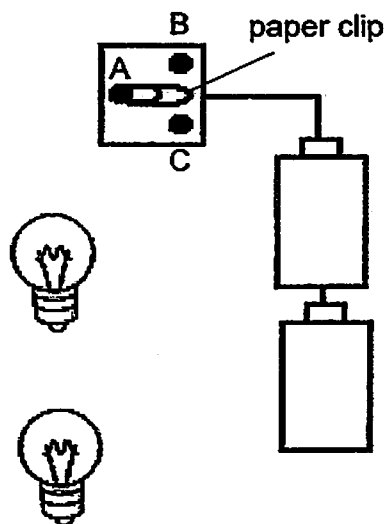

circuit Y

- (a) In circuit Y above, **DRAW** lines to complete the circuit such that when one bulb fused, the other bulb would remain lit. [1]

- (b) Compare circuits W and Y on page 44. State **ANOTHER** advantage of circuit Y over circuit W. [1]

---



---

- 43 Fidessa used identical batteries and light bulbs in 2 different electrical set-ups to compare the rate of evaporation of water in 2 different containers, J and K. Each container was initially filled with 800 ml of water.

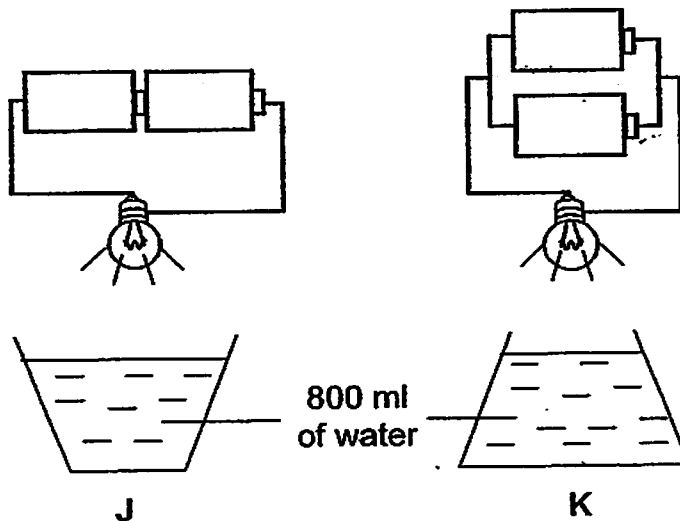

After an hour, Fidessa measured the volume of water left in each container and noticed that the volume of water left in container J was less than that in container K.

Based on the information above, answer the following questions:

- (a) Give two reasons to explain why the volume of water left in container J was less than that in container K. [2]

|          |  |
|----------|--|
| REASON 1 |  |
| REASON 2 |  |

- 44 Mary had a tall beaker containing a mixture of iron filings and similar sizes of styrofoam balls and silver ball-bearings.

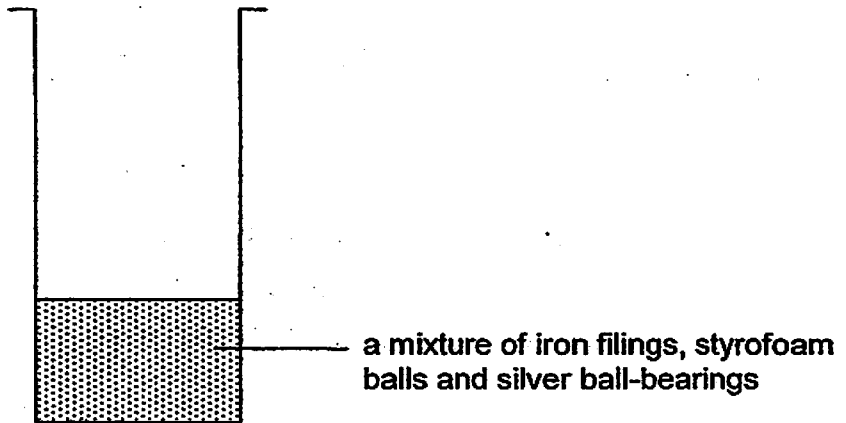

Mary was also given the list of items: a small fish net, a strong U-shaped magnet and 500 ml of water to separate the mixture in the beaker.

- (a) Using ALL the items given above, describe how Mary could separate the three items in the mixture without pouring out the items or getting her fingers wet. [2]

| Step | Procedure |
|------|-----------|
| 1    |           |
|      |           |
|      |           |
|      |           |
|      |           |
|      |           |
|      |           |

(b) Explain why Mary used only the ends of the U-shaped magnet to attract an object.

[1]

---

---

45 Joe conducted an experiment using 3 parachutes of different diameters, A, B and C, as shown in the diagram below.

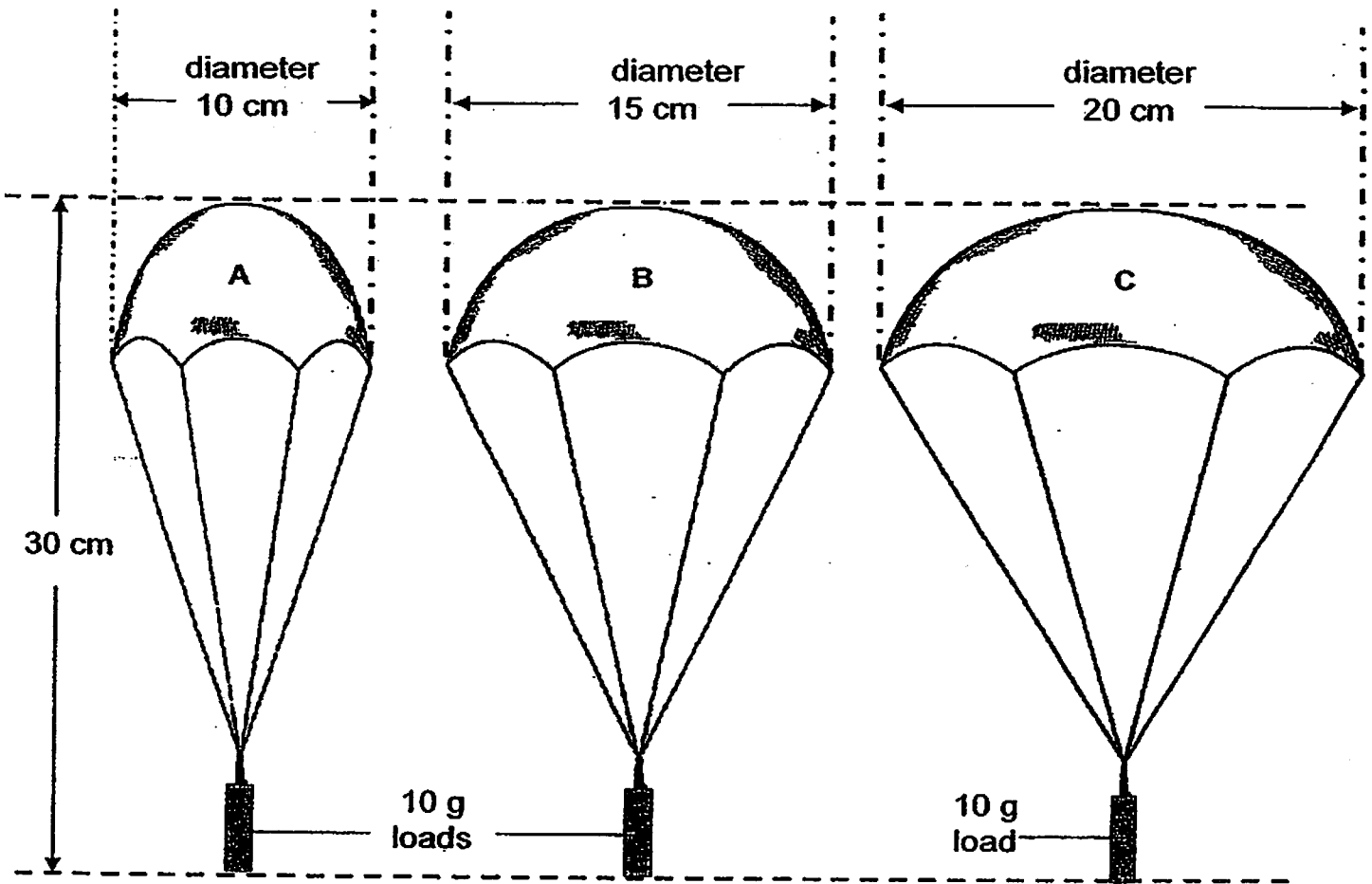

He dropped all 3 parachutes from the same height at the same location. He measured the time taken for each parachute to land on the ground and recorded his results as shown in the table below.

| parachute | number of trials | time taken to land on the ground / s | average time taken to land on the ground / s |
|-----------|------------------|--------------------------------------|--|
| A         | 1                | 4.7                                  | 5  |
|           | 2                | 5.2                                  |  |
|           | 3                | 5.1                                  |  |
| B         | 1                | 8.0                                  | 8  |
|           | 2                | 8.2                                  |  |
|           | 3                | 7.8                                  |  |
| C         | 1                | 12.0                                 | 12   |
|           | 2                | 11.8                                 |  |
|           | 3                | 12.2                                 |  |

Based on the information given on page 48, answer the following questions:

- (a) What was the aim of Joe's experiment? [1]

---

---

- (b) In order to conduct a fair test, state one **OTHER** variable that Joe must keep the same. [1]

---

---

46 Fahmy used the set-up as shown in the diagram below to find out how the mass of the load affects the extension of the spring.

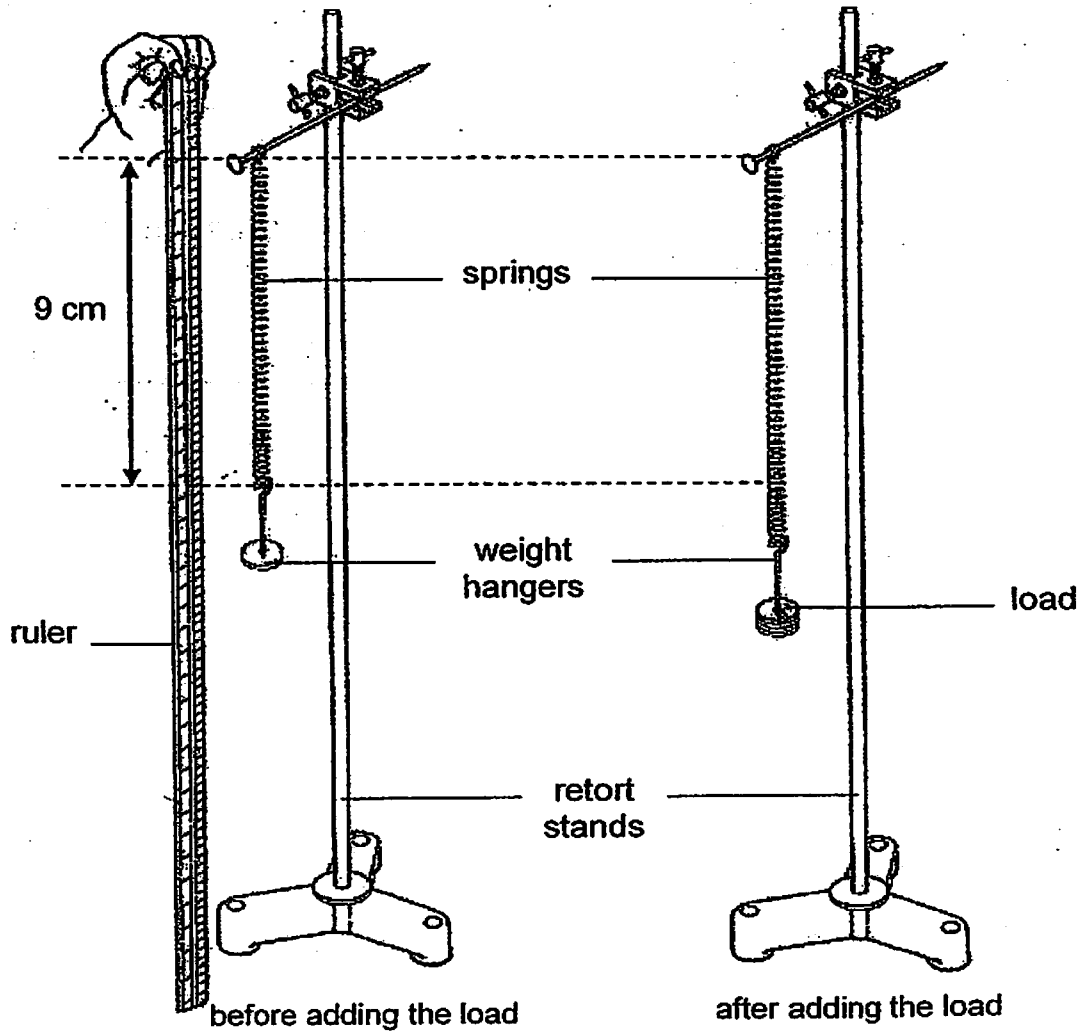

He conducted the experiment using load of a different mass, ONE at a time, and recorded part of his results in the table below.

| mass of load / g | extension of spring / cm |
|------------------|--------------------------|
| 0                | 0                        |
| 10               | 2                        |
| 20               | 4                        |
| 30               | 6                        |
| 40               | 8                        |
| 50               | 10                       |
| 60               | 12                       |

Based on the information on page 50, answer the following questions:

- (a) What would the extension of the spring be when a 90 g load was placed on the weight hanger? [1]

---

- (b) State the relationship between the extension of the spring and the mass of the load on the weight hanger. [1]

---

---

- (c) **SKETCH** a line graph to show the relationship between the length of the spring and the mass of the load on the weight hanger. [1]

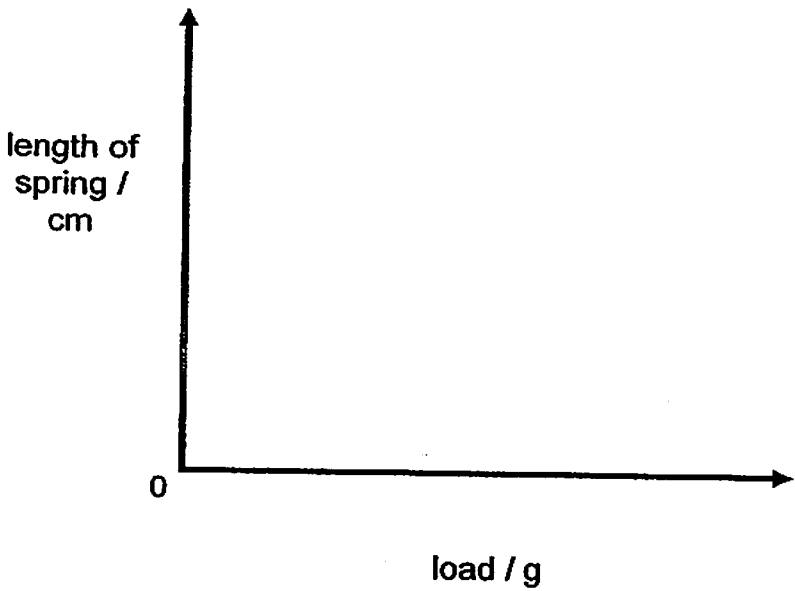

- END OF PAPER -

Setters: Ms Aishah, Mrs Lee K F, Mdm Ong S N and Mr Tan S W



# RAFFLES GIRLS' PRIMARY SCHOOL

## 2009 Primary 6 SCIENCE Preliminary Examination

Setters : Aishah Aris, Kar Fong, Shueh Nee, Siew Whatt

### ANSWER KEY

#### SECTION A (30 X 2 marks)

##### Multiple Choice questions

|    |   |     |   |     |   |     |   |     |   |     |   |
|----|---|-----|---|-----|---|-----|---|-----|---|-----|---|
| 1. | 2 | 6.  | 2 | 11. | 3 | 16. | 1 | 21. | 1 | 26. | 2 |
| 2. | 2 | 7.  | 3 | 12. | 3 | 17. | 2 | 22. | 3 | 27. | 3 |
| 3. | 4 | 8.  | 4 | 13. | 3 | 18. | 1 | 23. | 4 | 28. | 2 |
| 4. | 1 | 9.  | 2 | 14. | 1 | 19. | 3 | 24. | 2 | 29. | 1 |
| 5. | 1 | 10. | 2 | 15. | 1 | 20. | 4 | 25. | 4 | 30. | 1 |

#### SECTION B (40 marks)

| No. | Marks | Answers | Remarks   |   |
|-----|-------|---------|---|---|
| 31. | a     | 1       | one   |   |
|     | b     | 2       | <p>OR</p>   | <p>1m for correct drawing of wife &amp; daughter</p> <p>1m for correct indication of genetic information</p> <p>minus [1/2] for any line not correctly joined</p> |
| 32  | a     | 1       | To remove oxygen from the air   |   |
|     | b     | 1       | <u>The plant photosynthesised in the presence of sunlight to produce oxygen [1/2] that the lizard needs for respiration [1/2]</u> |   |

| No. | Marks | Answers | Remarks  |   |
|-----|-------|---------|--|---|
| 32  | c     | 1       | <p>Carbon dioxide that is given out by the lizard during respiration turned the limewater chalky.[1]</p> <p>Partial ans:<br/>           - The <u>limewater turned chalky</u> [1/2].<br/>           - <u>Carbon dioxide is released by the lizard during respiration</u> [1/2].</p> | [0] carbon dioxide is released by the lizard                  |
| 33  | a     | 2       | <ul style="list-style-type: none"> <li>- Use an equal amount of oil [1]</li> <li>- Use (equal amount of) pond water / tap water in both beakers [1]</li> </ul>   | [0] If did not specify the type of liquid used in beakers     |
|     | b     | 1       | To compare and confirm that the difference in the amount of water lost is due to the different number of leaves.   |   |
| 34  | a     | 1       | <p>Less competition for light/space since the other species of trees are unable to survive in such ground condition. OR</p> <p>The mud in the swamp is rich in nutrients.</p>  |   |
|     | b     | 1       | They enable the trees to be firmly rooted to the ground.   |   |
| 35  | a     | 1       | <p>Having sponges on itself helps it to blend with the surrounding[1/2], hence not easily attacked by predator [1/2].</p> <p>OR</p> <p>As the sponges on it are toxic [1/2], having these sponges prevented predators of the crab from attacking it [1/2].</p>                     |   |
|     | b     | 1       | <p>The crab protects the sponges from the nudibranchs. OR</p> <p>As the crab carries the sponges with it, the sponges can move around to escape from the nudibranchs / move around to feed on the planktons.</p>   |   |
| 36  | a     | 1       | A, D and B   | No partial mark   |
|     | b     | 2       | <ul style="list-style-type: none"> <li>- The hardest material does not mean that the material is the strongest [1]</li> <li>- The strength of the material to lift heavy loads is more important than its hardness.[1]</li> </ul>  | 1m for concept of hardest not directly proportion to strength |

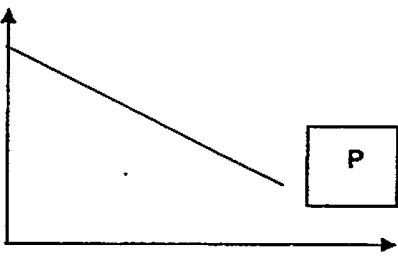
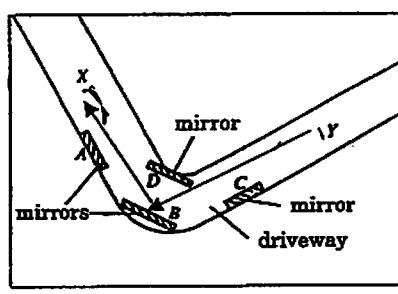
| No. | Marks | Answers | Remarks  |
|-----|-------|---------|--|
|     |       |         | recognizing that its strength is more important than its hardness.<br>Concept marking  |
| 37  | a     | 1       | Warm air rises, cold air sinks   |
|     | b     | 1       | It is more energy efficient to place the air-conditioner near the ceiling as the room would be cooled down faster as compared to if it is placed near the floor. OR<br><br>Warm air near the floor rises and is cooled by the air-conditioner. If the air-conditioner is placed near the ceiling, it can give out cool air that sinks to keep the entire room cold faster as compared to if it is placed near the floor. |
| 38  | a     | 1       | Potential energy $\rightarrow$ Kinetic energy $\rightarrow$ Potential energy   |
|     | b     | 1       |   |
|     | c     | 1       | At position A, the potential energy of the ball is the highest as it is at the greatest distance away from the ground. [1]   |
| 39  | a     | 1 1/2   | (i) Not possible to tell<br>(ii) True<br>(iii) Not possible to tell  |
|     | b     | 1/2     | Mirror B   |
|     | c     | 1       |   |

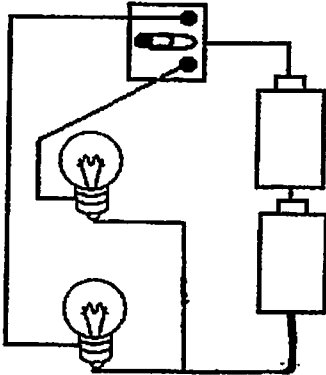
| No.  | Marks | Answers   | Remarks  |  |   |   |     |       |           |     |      |           |     |      |       |
|------|-------|-----------|--|--|---|---|-----|-------|-----------|-----|------|-----------|-----|------|-------|
| 40.  | a     | 1         | Iron- Q<br>Wood – P  | [1/2] each   |   |   |     |       |           |     |      |           |     |      |       |
|      | b     | 1         | (Iron) Q was a better conductor of heat than P (wood) so heat would be conducted away faster from the paper on Q than on P before the paper got burnt.   | Must compare; otherwise [0]                              |   |   |     |       |           |     |      |           |     |      |       |
| 41.  | a     | 1         | <ul style="list-style-type: none"> <li>Y expands more than X when heated. OR</li> <li>The rate of expansion of Y is greater than the rate of expansion of X.</li> </ul>  |  |   |   |     |       |           |     |      |           |     |      |       |
|      | b     | 1         | <table border="1"> <thead> <tr> <th>Alt.</th> <th>X</th> <th>Y</th> </tr> </thead> <tbody> <tr> <td>(1)</td> <td>brass</td> <td>aluminium</td> </tr> <tr> <td>(2)</td> <td>iron</td> <td>aluminium</td> </tr> <tr> <td>(3)</td> <td>iron</td> <td>brass</td> </tr> </tbody> </table>   | Alt.   | X | Y | (1) | brass | aluminium | (2) | iron | aluminium | (3) | iron | brass |
| Alt. | X     | Y         |  |  |   |   |     |       |           |     |      |           |     |      |       |
| (1)  | brass | aluminium |  |  |   |   |     |       |           |     |      |           |     |      |       |
| (2)  | iron  | aluminium |  |  |   |   |     |       |           |     |      |           |     |      |       |
| (3)  | iron  | brass     |  |  |   |   |     |       |           |     |      |           |     |      |       |
| 42   | a     | 1         |   | 1 or 0<br><br>Note: The bulbs are connected in parallel. |   |   |     |       |           |     |      |           |     |      |       |
|      | b     | 1         | The bulbs in circuit Y are brighter than the bulbs in circuit W.   |  |   |   |     |       |           |     |      |           |     |      |       |
| 43   | a     | 2         | <p>Reason 1<br/>The <u>greater exposed surface area of water in container J enabled the water in it to evaporate faster</u> [1] than that in container K.</p> <p>Reason 2<br/>The batteries connected in series in the circuit above container J <u>provided more heat energy to enable the water in container J to evaporate faster</u> than that in container K.</p> | 1 each<br>Must compare                                   |   |   |     |       |           |     |      |           |     |      |       |

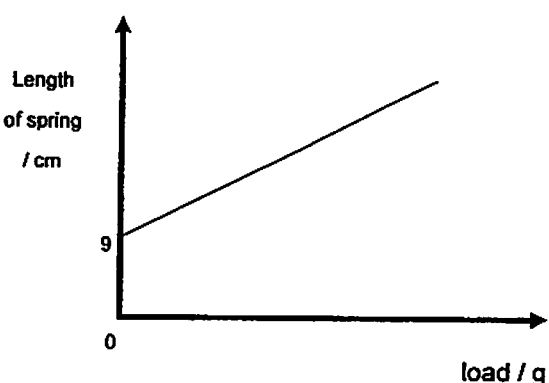
| No. | Marks | Answers | Remarks  |  |
|-----|-------|---------|--|--|
| 44  | a     | 2       | <ol style="list-style-type: none"> <li>Slide the strong U-shaped magnet along the sides of the beaker to attract and remove all the iron filings.</li> <li>Pour water into the mixture so that the styrofoam balls will float.</li> <li>Scoop up the floating styrofoam balls with the fish net.</li> <li>Pour away the water leaving behind only the silver ball-bearings.</li> </ol> <p>(Steps need not be in order; steps must be logical)<br/>Mark question as a whole, if there are illogical steps,[0]</p> | <p>[1/2] for each correct idea.</p> <p>Accept other relevant answer.</p> |
|     | b     | 1       | Magnetism is the strongest at the poles of a magnet.   |  |
| 45  | a     | 1       | To find out if the diameter of the parachute will affect the time the parachute takes to land on the ground.   |  |
|     | b     | 1       | Materials used to make the parachutes must be the same.  |  |
| 46  | a     | 1       | 18 cm  | -[1/2] for no units / wrong units.                                       |
|     | b     | 1       | The greater the mass of the load on the weight hanger, the greater the extension of the spring.  |  |
|     | c     | 1       |    | Note: If graph starts from 0, [0]  |

- END OF PAPER -